

Form A09

(April 2018)



The **ACT**[®]

2017 | 2018

In response to your request for Test Information Release materials, this booklet contains the test questions, scoring keys, and conversion tables used in determining your ACT scores. Enclosed with this booklet is a report that lists each of your answers, shows whether your answer was correct, and, if your answer was not correct, gives the correct answer.

If you wish to order a photocopy of your answer document—including, if you took the writing test, a copy of your written essay—please use the order form on the inside back cover of this booklet.



ENGLISH TEST

45 Minutes—75 Questions

DIRECTIONS: In the five passages that follow, certain words and phrases are underlined and numbered. In the right-hand column, you will find alternatives for the underlined part. In most cases, you are to choose the one that best expresses the idea, makes the statement appropriate for standard written English, or is worded most consistently with the style and tone of the passage as a whole. If you think the original version is best, choose "NO CHANGE." In some cases, you will find in the right-hand column a question about the underlined part. You are to choose the best answer to the question.

You will also find questions about a section of the passage, or about the passage as a whole. These questions do not refer to an underlined portion of the passage, but rather are identified by a number or numbers in a box.

For each question, choose the alternative you consider best and fill in the corresponding oval on your answer document. Read each passage through once before you begin to answer the questions that accompany it. For many of the questions, you must read several sentences beyond the question to determine the answer. Be sure that you have read far enough ahead each time you choose an alternative.

PASSAGE I

Albino Redwoods

At Henry Cowell State Park in Felton, California, a waxy white bush leans against the majestic trunk of a 500-year-old, 20-story-tall coastal redwood tree. The bush is distinctive, it has an unusual incandescence and only stands about four feet tall. Surprisingly, though, the bush is almost genetically identical to the enormous redwood that dwarfs it. The bush—a rare botanical anomaly—is an albino coastal redwood.

1. A. NO CHANGE
 B. distinctive, it has an unusual incandescence,
 C. distinctive; it has an unusual incandescence
 D. distinctive it has an unusual incandescence
2. F. NO CHANGE
 G. bush a rare botanical anomaly—
 H. bush, a rare botanical anomaly—
 J. bush—a rare botanical anomaly

1



1

These exceptional shrubs lack the most essential plant characteristic: the ability to produce chlorophyll, which absorbs light most strongly in the blue portion of the electromagnetic spectrum. 3 Without chlorophyll, photosynthesis cannot occur, leaving albino coastal

redwoods without a means of producing its own food.

Contrastingly, in order to survive, these plants become

parasites. Latching onto the roots of nearby redwoods to tap into their nutrients. During periods of drought,

albino redwoods often wither and enter a dormant state. Later, during periods of heavy rainfall, they

resurrect back to life and latch onto their hosts.

3. The writer is considering deleting the following clause from the preceding sentence (adjusting the punctuation as needed):

which absorbs light most strongly in the blue portion of the electromagnetic spectrum

Given that the information is accurate, should the writer make this deletion?

- A. Yes, because the information is implied by information in the previous paragraph.
 - B. Yes, because the information is irrelevant to the scope and focus of the paragraph.
 - C. No, because the information clarifies how albino coastal redwoods can survive without producing chlorophyll.
 - D. No, because the information clarifies why coastal redwood trees can grow to such astounding heights.
4. F. NO CHANGE
G. their
H. it's
J. its'
5. A. NO CHANGE
B. Accordingly,
C. Similarly,
D. Besides,
6. F. NO CHANGE
G. parasites and latching
H. parasites, latching
J. parasites; latching
7. A. NO CHANGE
B. introduce
C. invade
D. access
8. F. NO CHANGE
G. resurrect in reanimation to latch
H. revive to life again, latching
J. revive and latch back

1

Although these plants may seem like little more than botanical leeches, they are actually a testament

from the tree's remarkable genetics and adaptability. Coastal redwoods have six pairs of chromosomes. This allows them an extraordinary degree of genetic diversity. Every time a new coastal redwood sprouts, an abundance of possible genetic mutations can occur. Most of these mutations benefit the tree, such as making it more resistant to fungi or viruses. But on occasion an albino mutation of the forest can occur, creating this rare phenomenon.

Botanists appraise there are only about sixty albino coastal redwoods in the world. Geneticists are now

thinking more or less about the chromosomal makeup of these rare specimens. While scientists are still baffled by what function albino coastal redwoods

serve in forests. Conservationists continue to advocate for their preservation. At the very least, albino coastal redwoods are not only a rare phenomenon but also a stunning illumination in the diversity found in the natural world.

9. Given that all the choices are accurate, which one most effectively leads the reader from the preceding paragraph to the new paragraph?
- A. NO CHANGE
 - B. Although these plants have been found in the forests of Northern California,
 - C. While park rangers have made concerted efforts to protect these plants,
 - D. While these plants are not nearly as tall as other coastal redwoods,

10. F. NO CHANGE
G. since
H. to
J. in

11. The best placement for the underlined portion would be:
- A. where it is now.
 - B. after the word *occasion*.
 - C. after the word *creating*.
 - D. after the word *phenomenon* (and before the period).

12. F. NO CHANGE
G. interpret
H. estimate
J. foresee

13. The writer wants to emphasize that geneticists are now researching the genetic makeup of albino coastal redwoods more thoroughly. Which choice best accomplishes that goal?

- A. NO CHANGE
- B. delving deeper into
- C. looking haphazardly at
- D. intermittently exploring

14. F. NO CHANGE
G. forests, and conservationists
H. forests and conservationists
J. forests, conservationists

15. A. NO CHANGE
B. of the diversity found of
C. of the diversity found in
D. in the diversity found of

PASSAGE II

Diving the Bonne Terre Mine

In 1962, one of the main producers of lead in the United States for almost a century, the Bonne Terre Mine in Bonne Terre, Missouri, was shut down due to falling profits. With equipment and tools still deep within the mine, the entrance was boarded up, the pumps that had kept the mine dry for decades turned off. ¹⁶ 17 Now, the site is visited by

thousands of scuba divers every year, those who looked ¹⁸

for an unusual dive in what sometimes is considered as like ¹⁹ an underwater mining museum.

The abandoned mine is shaped like a giant cone, with each of its five levels becoming successively narrower. A series of chutes, passageways, and ore dumps connects the levels. Sprawling beneath the four-square-mile town of Bonne Terre, however, ²⁰ the mine contains

over eighty square miles of larger-than-life ²¹ rooms and at least seventeen miles of tunnels.

16. F. NO CHANGE
 G. tools (still deep within the mine)
 H. tools, still deep within the mine,
 J. tools, still deep within the mine
17. Which of the following true statements, if added here, would provide the best transition between the account of the mine's history and the description of its current use?
- A. The original 946 acres of land of the Bonne Terre Mine site were purchased in 1864 by the St. Joseph Lead Company.
 B. Groundwater began to seep in, eventually filling most of the mine and forming one of the world's largest underground lakes.
 C. Visitors not interested in scuba diving are welcome to take walking tours or boat tours of the upper levels of the mine.
 D. The views of the mine from underwater are breathtaking—the mine is both a natural and a human-made wonder.
18. F. NO CHANGE
 G. who were to look
 H. are to look
 J. looking
19. A. NO CHANGE
 B. is labeled as it may as
 C. might be called
 D. seems as
20. F. NO CHANGE
 G. for example,
 H. therefore,
 J. DELETE the underlined portion.
21. Which choice emphasizes the large size of the rooms of the mine with the clearest and most specific reference to scale?
- A. NO CHANGE
 B. stadium-sized
 C. unbelievable
 D. expansive

1 ■ ■ ■ ■ ■ ■ ■ ■ ■ ■ 1

The cool water that fills the mine that is below the
²²
city of Bonne Terre is remarkably clean and clear.

[1] ²²Divers enter the mine through a small outbuilding in Bonne Terre. [2] At the very bottom of the mine still stands the timekeeper's shack, where workers clocked in at the beginning of a shift. [3] Inside, 500,000-watt floodlights gleam the dry top level of the mine, where walking tours are held. [4] The main diving docks are about a quarter mile within the mine, on the second level. [5] On guided tours, divers explore tunnels filled with ore carts, rock drills, dynamite boxes, and other artifacts from the mine's possession. [6] Smooth walls and ceilings

²⁵
stretch for miles, and shimmer with deposits of cobalt,
²⁶

copper, calcium, and iron; pillars of unexcavated rock support the ceilings. [7] Near the shack, a rusting

locomotive lies on its side. 28

The site was explored by internationally renowned French diver
²⁹
Jacques Cousteau and has been featured in many travel and adventure publications. Divers from around the world visit the Bonne Terre Mine site keep swimming into a fascinating past.
³⁰

22. F. NO CHANGE
G. this sprawling, cone-shaped mine
H. this mine with five levels
J. the mine

23. A. NO CHANGE
B. shack, there
C. shack; where
D. shack,

24. F. NO CHANGE
G. illuminate
H. radiate
J. enlighten

25. A. NO CHANGE
B. the working days of the mine.
C. when it worked.
D. then.

26. F. NO CHANGE
G. miles and shimmer
H. miles, and shimmer,
J. miles and shimmer,

27. Which of the following alternatives to the underlined portion would NOT be acceptable?
A. iron; throughout the mine, pillars
B. iron, while pillars
C. iron, pillars
D. iron. Pillars

28. For the sake of the logic and coherence of this paragraph, Sentence 2 should be placed:
F. where it is now.
G. after Sentence 3.
H. after Sentence 4.
J. after Sentence 6.

29. Given that all the choices are accurate, which one provides the clearest and most relevant information at this point in the essay?
A. NO CHANGE
B. someone many people have heard of named
C. winner of awards in several areas
D. tourist and Frenchman

30. F. NO CHANGE
G. as it swims
H. that swims
J. to swim

PASSAGE III

Pitch Perfect

Even at age seven, Mozart presented³¹ audiences with his musical talents, including the ability to identify accurately any note he heard.

This aptitude, recognizing notes without aid³²—is called

absolute pitch. People with absolute pitch usually possess related musical skills, such as being able to sing any requested note perfectly.

For decades, the fraction sited³⁴ in scientific literature has been that only one person per ten thousand has absolute pitch. Such rarity renders absolute pitch so wicked sweet³⁵ to scientists, many of whom have long suspected that the ability has a genetic basis. Absolute pitch appears to run in families, after all. And in 2009 a team led by geneticist Jane Gitschier found positive correlation between specific chromosomes and absolute pitch.

On the other hand, psychologist Diana Deutsch, in arguing³⁶ that language is key to a person's chances of having absolute pitch. Deutsch found that people fluent in "tone languages"—such as Mandarin, where a word conveys different meanings depending on the pitch in which it is spoken—were much more likely to have absolute pitch than speakers of English and other nontone languages. One of Deutsch's studies paraded³⁷ that more than 90 percent of music students fluent in a tone language had absolute pitch.

31. Which choice most clearly indicates the audiences' reaction to young Mozart's musical talents?
- A. NO CHANGE
 - B. aimed to entertain
 - C. appeared before
 - D. dazzled
32. F. NO CHANGE
G. aptitude—recognizing notes without aid—
H. aptitude—recognizing notes without aid,
J. aptitude, recognizing notes without aid
33. A. NO CHANGE
B. pitch and those people
C. pitch and people
D. pitch, people
34. F. NO CHANGE
G. numeral sited
H. figure cited
J. digit cited
35. A. NO CHANGE
B. a problematic phenomenon that presents a captivating conundrum
C. all the more fascinating
D. totally nifty
36. F. NO CHANGE
G. Deutsch argues
H. Deutsch. She argues
J. Deutsch, who argues
37. A. NO CHANGE
B. broadcast
C. showed
D. bared

Clearly, that's dramatically higher than the

³⁸

previously mentioned statistic of one person

³⁹

per ten thousand.

Deutsch suggests that children learning tone

⁴⁰

languages develop the ability to associate pitch with

⁴⁰

meaning, which is analogous to someone with absolute

pitch associating a pitch with the name of the note.

In early childhood, as the brain goes through a phase

of development during which it is primed to learn

language, which can likewise be able to learn

⁴¹

absolute pitch. 42 If a child is studying music during this particular period, that further increases his or her chances of developing absolute pitch.

As for the dismal chances of learning absolute pitch

⁴³

as an adult, the odds aren't good: there has never

⁴⁴

been a proven case of success.

38. F. NO CHANGE
G. With this in mind,
H. As a result,
J. Besides,
39. Given that all the choices are accurate, which one most clearly suggests that the ideas about the prevalence of absolute pitch are changing?
A. NO CHANGE
B. often referred to
C. once-accepted
D. infinitesimal
40. F. NO CHANGE
G. suggests, that children learning tone languages,
H. suggests that children, learning tone languages,
J. suggests, that children learning tone languages
41. A. NO CHANGE
B. the brain may
C. to
D. DELETE the underlined portion.
42. At this point, the writer is considering dividing the paragraph into two. Should the writer begin or not begin a new paragraph here, and why?
F. Begin a new paragraph, because the essay shifts at this point from focusing on children and absolute pitch to focusing on adults and absolute pitch.
G. Begin a new paragraph, because it would separate the ideas about language development and absolute pitch from the essay's conclusion.
H. DO NOT begin a new paragraph, because doing so would establish a link between early childhood music education and absolute pitch.
J. DO NOT begin a new paragraph, because doing so would interrupt the discussion of childhood influences on absolute pitch.
43. A. NO CHANGE
B. learning absolute pitch so that it is something you have acquired
C. a grown-up learning absolute pitch
D. acquiring absolute pitch
44. F. NO CHANGE
G. good; and
H. good,
J. good

Question 45 asks about the preceding passage as a whole.

45. Suppose the writer's primary purpose had been to equally consider Gitschier's and Deutsch's theories regarding the reasons some people develop absolute pitch. Would this essay accomplish that purpose?
- A. Yes, because it considers both of the theories with equivalent depth and breadth.
 - B. Yes, because it clearly outlines the reasons why Gitschier's theory is the correct one.
 - C. No, because it explores Deutsch's theory more thoroughly than it does Gitschier's.
 - D. No, because it displays a bias against Deutsch's theory, preventing a balanced comparison.

PASSAGE IV

George Masa and the Smoky Mountains

Masa Knob, a densely forested peek in Great Smoky ⁴⁶

Mountains National Park, isn't as majestic a park attraction ⁴⁷ as Clingmans Dome or Laurel Falls. It's a humble

landmark named for a man who tirelessly explored, ⁴⁸

documented, and fought to protect and would become ⁴⁹ the most visited national park in the United States.

Japanese immigrant, Iizuka Masahara, adopted ⁵⁰ the name George Masa in 1915, when he took a job as a bellman at an upscale hotel in Asheville, North Carolina.

He often took pictures of hotel guests. Masa's photos depict prosperous vacations, some enjoying hikes ⁵¹ organized by Masa himself. Three years after

settling in Asheville, which was when Masa ⁵² opened a photography studio.

- 46. F. NO CHANGE
G. forested peak
H. forest peak
J. forest peek
- 47. A. NO CHANGE
B. so much a majestic
C. as majestic as the
D. majestically a
- 48. F. NO CHANGE
G. from
H. upon
J. of
- 49. A. NO CHANGE
B. protect it, which
C. protect, which
D. protect what
- 50. F. NO CHANGE
G. immigrant, Iizuka Masahara
H. immigrant Iizuka Masahara,
J. immigrant Iizuka Masahara
- 51. A. NO CHANGE
B. vacationers,
C. vacation scenes,
D. vacationing,
- 52. F. NO CHANGE
G. it was then that
H. at which point
J. DELETE the underlined portion.

The fog-shrouded mountains surrounding Asheville frequently lured Masa, with heavy, unwieldy camera equipment in tow, out of the studio he'd opened in Asheville. Morning ⁵³ hikes became weeks-long expeditions. To get the perfect shot, Masa would scale the highest mountains, lugging ⁵⁴ his equipment on his back. He sometimes waited hours for the clouds to arrange themselves to his liking before he took a picture.

Masa's measuring instruments were innovative. ⁵⁵ Using an odometer mounted on the detached front end of a bicycle, Masa measured his routes. He pushed the contraption across the steep terrain, hiking and measuring, measuring and hiking, year after year. From these measurements, he produced detailed maps.

Masa made it his mission to ensure that the land he treasured would be preserved as a national park. He gave his photos and maps to prominent Asheville visitors, recruiting First Lady Grace Coolidge and wealthy philanthropist John D. Rockefeller Jr., among others, to ⁵⁶

join the park campaign. In reality, ⁵⁷ to build support from the wider public, Masa distributed thousands of postcards of his photos.

53. A. NO CHANGE
 B. his studio and into the mountains.
 C. his studio.
 D. there.
54. Which choice most effectively emphasizes that Masa's equipment was unwieldy?
 F. NO CHANGE
 G. transporting
 H. carrying
 J. taking
55. Given that all the statements are true, which one provides the most effective transition from the preceding paragraph to this paragraph?
 A. NO CHANGE
 B. Masa wasn't content only exploring and photographing the mountains, however.
 C. Masa's photos of the Smoky Mountains were not only detailed, but also artistic.
 D. Bicycling was another of Masa's interests.
56. F. NO CHANGE
 G. amid other big shots,
 H. and so forth,
 J. et cetera,
57. A. NO CHANGE
 B. All in all,
 C. Then,
 D. Thus,

Great Smoky Mountains National Park was established in 1934, a year after Masa's death. Although not many park visitors climb Masa Knob or know about it's namesake and advocate,

58

I think they should.

59

58. F. NO CHANGE
 G. they're
 H. their
 J. its
59. Which choice most effectively concludes the sentence and the essay?
 A. NO CHANGE
 B. archivists still search for Masa's photographs today.
 C. they all owe their visit in part to George Masa.
 D. it can be found just off the Appalachian Trail.

Question 60 asks about the preceding passage as a whole.

60. Suppose the writer's primary purpose had been to describe how an artist discovered and developed his or her talent. Would this essay accomplish that purpose?
 F. Yes, because the writer indicates that visitors to Asheville inspired Masa to try out photography.
 G. Yes, because the writer describes tools that Masa created to refine his photography techniques.
 H. No, because the writer focuses on how Masa used his talents to help explore and preserve a specific area.
 J. No, because the writer admits that not many visitors to Great Smoky Mountains National Park know about Masa.

PASSAGE V

Cozy Graffiti

In 2005, Houston shop owner Magda Sayeg knit a blue-and-pink cozy, or fitted cover, for the street-side door handle of her store. It was a slow day; Sayeg was bored. To her surprise, the seemingly out-of-place little cozy drew a lot of attention and often made people smile. Inspired by the effects, Sayeg knit a leg warmer for the stop sign on the corner. This time, drivers actually pulled over for a closer look. Some people even took pictures of

61

61. Which of the following alternatives to the underlined portion would NOT be acceptable?
 A. Because Sayeg was inspired by the effects, she
 B. The effects, which were inspiring for Sayeg,
 C. Sayeg, taking inspiration from the effects,
 D. The effects were inspiring for Sayeg; she

the sign. As Sayeg expanded her territory around Houston, her then-anonymous projects gained notoriety online and in newspapers, sparking similar endeavors by knitters and crocheters around the globe.

Adopting the utterances of graffiti, these yarn artists commonly refer to the act of covering something with

knitted or crocheted yarn such as "tagging." They take measurements of an object they wish to cover, stitch at home, and then quietly wrap the object during the night.

Rather, in the morning, a park full of trees wrapped in striped leg warmers welcomes joggers. Giant metal chain

links on a wharf appear covered in violet, green, white,

blue. Sidewalk cracks being filled with skinny, knitted ropes of magenta.

Some yarn graffiti artists mainly want to surprise people, offering a bit of homey comfort

where we're least expected. Others, however,

aim for a more political message, they drape cannons and tanks in colorful crocheted afghans.

62. F. NO CHANGE
G. verbalizations
H. language
J. talk

63. A. NO CHANGE
B. like
C. as
D. to

64. F. NO CHANGE
G. Specifically, in
H. Meanwhile, in
J. In

65. The writer wants to emphasize the idea that wrapping an object in yarn has the effect of softening the object's appearance. Which choice best accomplishes that goal?

A. NO CHANGE
B. new with freshly knitted yarn in
C. highlighted in vibrant colors of
D. swaddled in fuzzy hues of

66. F. NO CHANGE
G. cracks, which are
H. cracks are
J. cracks

67. A. NO CHANGE
B. artists, by mainly wanting
C. artists who mainly want
D. artists, mainly wanting

68. F. NO CHANGE
G. you're
H. one's
J. it's

69. A. NO CHANGE
B. such yarn artists have draped
C. draping
D. they might drape

In 2011, knitter Jessie Hemmons decided she'd had enough of people snapping pictures of the bronze statue of Rocky (a fictional boxer) in front of the Philadelphia Museum of Art without ever going inside the museum. She crafted a bright pink hoodie for the muscular figure, who was played by Sylvester Stallone in the Rocky movies.

Although yarn tagging is a form of graffiti, it's tolerated more often than other forms because the yarn can be simply snipped off. This may be the aspect that allows people to smile as they drop coins into a cozy, purple parking meter and to consider the artist's sweet—or edgy point.

70. F. NO CHANGE
 G. knitter—Jessie Hemmons—
 H. knitter, Jessie Hemmons,
 J. knitter Jessie Hemmons,
71. A. NO CHANGE
 B. museum that they are standing in front of.
 C. building, which features works of art.
 D. Philadelphia Museum of Art.
72. Given that all the choices are accurate, which one best supports the idea the writer is putting forth at this point in the essay?
 F. NO CHANGE
 G. figure, which stands at the bottom of the seventy-two steps leading up to the museum entrance.
 H. figure and carried a stepladder to the site so she could reach the statue.
 J. figure, adding an embroidered imperative: "GO SEE THE ART."
73. A. NO CHANGE
 B. its' tolerated more often then
 C. it's tolerated more often then
 D. its tolerated more often than
74. F. NO CHANGE
 G. sweet—or edgy—
 H. sweet, or edgy
 J. sweet or edgy,

Question 75 asks about the preceding passage as a whole.

75. Suppose the writer's primary purpose had been to offer an overview of a cultural phenomenon. Would this essay accomplish that purpose?
 A. Yes, because it describes the range of Sayeg's yarn graffiti projects from the door handle cozy to larger projects throughout Houston.
 B. Yes, because it briefly traces the development of yarn graffiti, offers examples, and discusses the variety of artists' intentions.
 C. No, because it explains what yarn graffiti is but suggests that few people are involved in it.
 D. No, because it focuses mainly on creating a profile of Sayeg as the first yarn graffiti artist.

END OF TEST 1

STOP! DO NOT TURN THE PAGE UNTIL TOLD TO DO SO.

**MATHEMATICS TEST**

60 Minutes—60 Questions

DIRECTIONS: Solve each problem, choose the correct answer, and then fill in the corresponding oval on your answer document.

Do not linger over problems that take too much time. Solve as many as you can; then return to the others in the time you have left for this test.

You are permitted to use a calculator on this test. You may use your calculator for any problems you choose,

but some of the problems may best be done without using a calculator.

Note: Unless otherwise stated, all of the following should be assumed.

1. Illustrative figures are NOT necessarily drawn to scale.
2. Geometric figures lie in a plane.
3. The word *line* indicates a straight line.
4. The word *average* indicates arithmetic mean.

1. A line in the standard (x,y) coordinate plane passes through the points $(-2,-6)$ and $(5,3)$. The slope of the line:
 - A. is positive.
 - B. is zero.
 - C. is negative.
 - D. is undefined.
 - E. cannot be determined from the given information.

DO YOUR FIGURING HERE.

2. What is the sum of the complex numbers $3 - 4i$ and $5 + 3i$?
 - F. 7
 - G. 27
 - H. $-1 + 8i$
 - J. $8 - i$
 - K. $15 - 12i$
3. Last year at RT University, the ratio of the number of students accepted to the number of students applying for admission was 2 to 7. RT University accepted 630 students last year. How many students applied to RT University last year?
 - A. 810
 - B. 1,260
 - C. 2,205
 - D. 2,835
 - E. 4,410



4. Three line segments intersect as shown in the figure below, forming angles with measures of 150° , 40° , and x° , respectively. What is the value of x ?

- F. 95
G. 85
H. 80
J. 75
K. 70

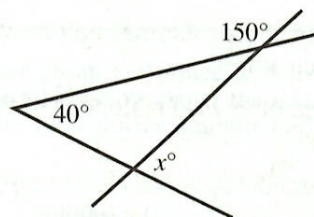

DO YOUR FIGURING HERE.

5. A carnival game is played using an open box with a rectangular bottom measuring 6 inches by 13 inches. A square with side lengths of 4 inches is painted on the bottom of the box. The game is played by dropping a small bead into the open box. If the bead comes to rest in the painted square, the player wins a prize. Assuming a bead dropped into the box comes to rest at a random spot on the bottom of the box, which of the following is closest to the probability that the bead comes to rest in the painted square?

- A. 0.05
B. 0.10
C. 0.21
D. 0.31
E. 0.67

6. What is the slope-intercept form of $9x - y - 5 = 0$?

- F. $y = -9x - 5$
G. $y = -9x + 5$
H. $y = 9x - 5$
J. $y = 9x + 5$
K. $y = 5x - 9$

7. The line below contains X , Y , and Z , in that order. The ratio of the length of \overline{XY} to the length of \overline{YZ} is 5:9. If it can be determined, what is the ratio of the length of \overline{XY} to the length of \overline{XZ} ?



- A. 5:14
B. 5:4
C. 9:5
D. 14:5
E. Cannot be determined from the given information

8. The solution set of $2x + 4 \geq -8$ is the set of all real values of x such that:

- F. $x \geq -8$
G. $x \geq -6$
H. $x \leq -6$
J. $x \geq -2$
K. $x \leq -2$



9. Which of the following is equivalent to $(a^3)^{21}$?

- A. $63a$
- B. $24a$
- C. $3a^{21}$
- D. a^{24}
- E. a^{63}

DO YOUR FIGURING HERE.

10. If $f(x) = 3x^2 + 7x - 8$, then $f(-3) = ?$

- F. -47
- G. -2
- H. 2
- J. 40
- K. 52

11. Two sides of a triangle are equal in length. The third side is 3 centimeters longer than either of the other 2 sides. Given that the perimeter of the triangle is 93 centimeters, what is the length, in centimeters, of the longest side?

- A. 29
- B. 30
- C. 31
- D. 33
- E. 34

12. The 220 graduating seniors of Madison High School will sit in the center section of the school auditorium at the graduation ceremony. How many rows of seats will be needed to seat all of the graduating seniors if the first row has 10 seats and each succeeding row has 2 more seats than the previous row?

- F. 10
- G. 11
- H. 12
- J. 15
- K. 30

13. In the standard (x,y) coordinate plane, the point $(3,-7)$ is the midpoint of the line segment with endpoints $(9,-11)$ and:

- A. $(-3,-25)$
- B. $(-3,-3)$
- C. $(3,-2)$
- D. $(3,3)$
- E. $(6,-9)$



Use the following information to answer questions 14–16.

DO YOUR FIGURING HERE.

A community theater group performed at 5 local schools. For each school, the table below shows the total number of tickets sold and the total dollar amount collected from ticket sales.

School	Number of tickets sold	Ticket sales
A	200	\$1,400
B	250	\$1,650
C	300	\$1,800
D	150	\$1,350
E	275	\$1,625

14. At School A, only 2 types of tickets were sold: premium tickets for \$10 each and value tickets for \$6 each. How many value tickets were sold at School A?
- F. 22
G. 50
H. 100
J. 150
K. 178
15. The theater group had to pay each school a facility charge. For use of its facility, School C charged the theater group 10% of the ticket sales and a fixed fee of \$200. How much money did School C charge the theater group for use of its facility?
- A. \$180
B. \$200
C. \$210
D. \$218
E. \$380
16. What is the difference between the median and the mean number of tickets sold at the 5 schools?
- F. 75
G. 65
H. 50
J. 40
K. 15
-
17. What is the area, in square decimeters, of a right triangle with side lengths of 10 dm, 26 dm, and 24 dm?
- A. 432
B. 312
C. 260
D. 240
E. 120



18. The mean of a list of 7 numbers is 85. The first 6 numbers on the list are 82, 93, 68, 93, 70, and 98. What is the 7th number on the list?

F. 83
G. 84
H. 90
J. 91
K. 93

19. Which of the following is the sine of the smallest angle in a right triangle with side lengths 7, 24, and 25 inches, respectively?

A. $\frac{7}{25}$
B. $\frac{7}{24}$
C. $\frac{24}{25}$
D. $\frac{24}{7}$
E. $\frac{25}{7}$

20. In the figure shown below, all angles are right angles, and the side lengths given are in feet. What is the area, in square feet, of the figure?

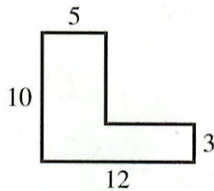

F. 49
G. 71
H. 86
J. 105
K. 120

21. A triangle has a perimeter of 26 cm and sides of length x cm, $(x + 3)$ cm, and $(x + 5)$ cm. What is the value of x ?

A. 6
B. $8\frac{2}{3}$
C. 9
D. 11
E. 26

22. A truck sprang a leak in its radiator, which held 480 ounces of fluid when it started to leak. Assuming the truck continues at 35 mph and its radiator leaks 4 ounces of fluid per minute, how many *miles* will the truck travel before the radiator is empty?

F. 13.7
G. 17.5
H. 35.0
J. 70.0
K. 120.0

DO YOUR FIGURING HERE.



23. An ice cream shop sells ice cream cones with exactly 1 of 3 ice cream flavors in the cone. The 3 flavors are vanilla, chocolate, and strawberry. Last Saturday, the shop sold 42 cones. It sold 11 more with chocolate than with vanilla and 2 more with vanilla than with strawberry. How many cones with strawberry ice cream did the shop sell that Saturday?

A. 9
 B. 11
 C. 14
 D. 20
 E. 27

DO YOUR FIGURING HERE.

24. In $\triangle ABC$ below, D is the midpoint of \overline{CB} , $\angle ABC$ is a right angle, $AB = 8$ m, and $AC = 10$ m. What is AD , in meters?

F. $\sqrt{41}$
 G. $\sqrt{73}$
 H. $\sqrt{82}$
 J. $\sqrt{91}$
 K. $\sqrt{105}$

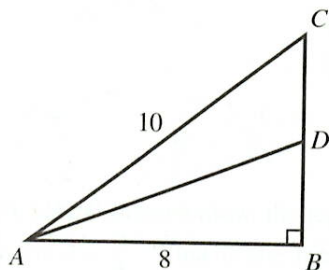

25. Lyman has plotted 5 points in the standard (x,y) coordinate plane below. He then plots a new point as follows: the x -coordinate of the new point is the mean of the x -coordinates of the 5 points already plotted; the y -coordinate of the new point is the mean of the y -coordinates of the 5 points already plotted. Which of the following ordered pairs gives the coordinates of Lyman's new point?

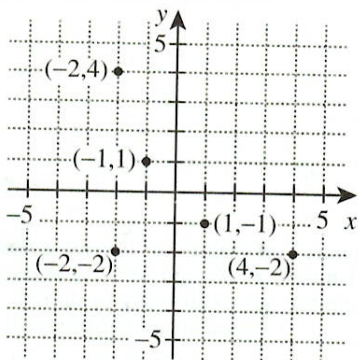

A. $(-2, -2)$
 B. $(-1, -1)$
 C. $(0, 0)$
 D. $(1, 1)$
 E. $(2, 2)$



26. The 1st and 2nd terms of a certain geometric sequence are 10 and -5 , respectively. What is the 5th term of the geometric sequence?

F. $-\frac{5}{8}$
 G. $-\frac{5}{16}$
 H. $\frac{5}{8}$
 J. $\frac{5}{16}$
 K. $\frac{5}{32}$

27. Alani works 8 hours per day 5 days each week at a custom embroidery shop. Each day Alani is paid either \$1.00 per shirt that she stitches or \$10.00 per hour, whichever daily amount is higher. Alani stitched the following numbers of shirts: 60 on Monday, 52 on Tuesday, 85 on Wednesday, 80 on Thursday, and 90 on Friday. What is Alani's total pay for these 5 days?

A. \$367.00
 B. \$400.00
 C. \$415.00
 D. \$457.70
 E. \$587.20

28. Which of the following most precisely describes the roots of the equation $5x^2 + 7x + 2 = 0$?

F. 1 rational (double) root
 G. 1 irrational (double) root
 H. 2 rational roots
 J. 2 irrational roots
 K. 2 complex roots (with nonzero imaginary parts)

29. Paula is planning a course for a bike race. The course is in the shape of a right triangle, as shown below. Participants will begin at A , ride directly to B , then directly to C , and directly back to A . Paula wants to put a rest stop at the halfway point on the course. How many miles past B will the rest stop be?

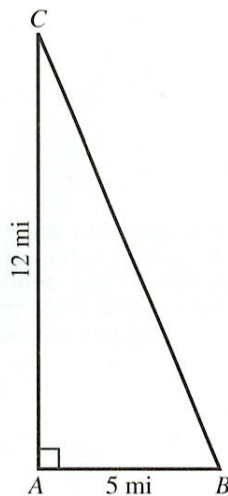

A. 3
 B. $6\frac{1}{2}$
 C. 8
 D. 10
 E. 13

DO YOUR FIGURING HERE.



30. Adams High School has 120 students, and $\frac{1}{3}$ of the students are taking Literature. Of the students NOT taking Literature, $\frac{1}{4}$ are taking Composition. No students are taking both Literature and Composition. How many students are taking Composition?

F. 10
G. 20
H. 30
J. 40
K. 80

31. For what value of x is the equation $\sqrt{x} + \sqrt{9} = \sqrt{36}$ true?

A. 2
B. 3
C. 4
D. 9
E. 27

32. In the right triangle $\triangle ABC$ shown below, the length of \overline{BC} is 12 feet and $\sin A = \frac{3}{4}$. What is the length, in feet, of \overline{AC} ?

F. 2
G. 4
H. $4\sqrt{7}$
J. 16
K. 20

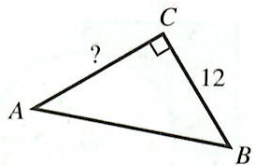

33. What integer does $3(\log_2 16)$ equal?

A. 12
B. 24
C. 64
D. 96
E. 768

34. A bag contains several marbles. On 3 successive draws with replacement, a red marble is drawn from the bag each time. Which of the following statements *must* be true about the marbles in the bag?

F. At least 1 marble is red.
G. Exactly 1 marble is red.
H. Exactly 3 marbles are red.
J. All the marbles are red.
K. The bag contains more red marbles than marbles of other colors.

DO YOUR FIGURING HERE.



Use the following information to answer questions 35–37.

Students and adults from Western High School visited an amusement park on a field trip. The amusement park charged \$25 for each adult ticket and \$20 for each student ticket. Before the trip, the students were given this information about the Happy Dragon roller coaster: the average speed of the roller coaster is 50 miles per hour, and 1 ride on the roller coaster track is completed in 2.25 minutes. A graph showing the height above level ground, in feet, with respect to the time into the ride, in seconds, is given below.

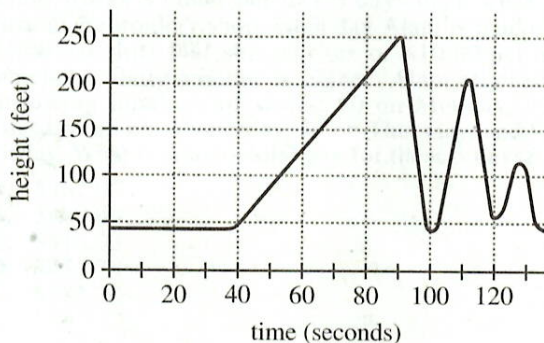

35. Which of the following values is closest to the total distance traveled, in miles, during 1 complete ride on the roller coaster track?
- A. 0.8
B. 1.9
C. 2.3
D. 2.7
E. 9.4
36. The roller coaster is at a height of at least 235 feet for a total of 5 seconds during each complete ride. Which of the following is closest to the percent of the time during a complete ride that the roller coaster is at a height of at least 235 feet?
- F. 1%
G. 4%
H. 19%
J. 33%
K. 45%
37. Which of the following values is closest to the average slope, in feet per second, of the graph on the interval between 40 seconds and 90 seconds?
- A. $\frac{1}{4}$
B. $\frac{7}{9}$
C. $2\frac{1}{4}$
D. $2\frac{7}{9}$
E. 4

DO YOUR FIGURING HERE.



38. The value of $x^5(0.5x^2 + 2.5x + 6)$ is between which of the following numbers when $x = 10$?

DO YOUR FIGURING HERE.

- F. 5×10^4 and 6×10^4
 G. 8×10^4 and 9×10^4
 H. 5×10^6 and 6×10^6
 J. 8×10^6 and 9×10^6
 K. 1×10^7 and 1×10^8
39. For which of the following data sets is the difference between the mean and the median the greatest?
- A. {10, 10, 10, 10}
 B. {10, 10, 15, 20}
 C. {10, 15, 15, 15}
 D. {10, 15, 15, 100}
 E. {10, 20, 90, 100}

40. Pablo has a deck and pool in his backyard. The deck's shape is a rectangle with a semicircle removed and is shown shaded in the figure below. The lengths of the straight sides of the deck are given in feet. Pablo plans to cover the top of the deck with stain. To decide how much stain to purchase, he needs to find the area of the top of the deck. To the nearest square foot, what is the area of the top of the deck?

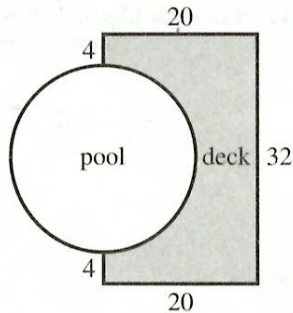

- F. 110
 G. 226
 H. 238
 J. 332
 K. 414
41. A 3-foot-wide brick sidewalk is laid around a rectangular swimming pool. The outside edge of the sidewalk measures 30 feet by 40 feet, as shown in the figure below. What is the perimeter, in feet, of the swimming pool?

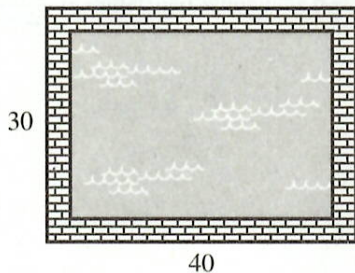

- A. 70
 B. 116
 C. 140
 D. 816
 E. 1,200



42. Given the functions $f(x) = x^2$ and $g(x) = \frac{1}{4-x}$, what is $g(f(x))$?

F. $\frac{1}{4-x^2}$

G. $\frac{1}{(4-x)^2}$

H. $\frac{1}{16-x^2}$

J. $\frac{x^2}{4-x}$

K. $\frac{x^2}{4-x^2}$

DO YOUR FIGURING HERE.

43. A circle has a circumference of $2\pi\sqrt{2}$ feet. What is the area, in square feet, of the circle?

A. $\pi\sqrt{2}$

B. $2\pi\sqrt{2}$

C. 2π

D. 4π

E. 8π

44. In the standard (x,y) coordinate plane, the coordinates of the y -intercept of the graph of the function $y = f(x)$ are $(0,-2)$. What are the coordinates of the y -intercept of the graph of the function $y = f(x) - 3$?

F. $(0,-5)$

G. $(0,-3)$

H. $(0,-2)$

J. $(0, 1)$

K. $(0, 6)$

45. Which of the following is an equation of a parabola that passes through the 3 points labeled in the standard (x,y) coordinate plane below?

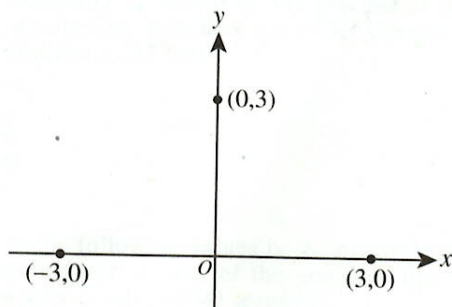

A. $y = -\frac{1}{3}(x-3)(x+3)$

B. $y = -(x-3)^2(x+3)$

C. $y = -(x-3)(x+3)^2$

D. $y = (x-3)^2(x+3)$

E. $y = \frac{1}{3}(x-3)(x+3)$



46. As x continually increases in value without bound, the value of $\frac{x}{x+3}$ most closely approaches:

DO YOUR FIGURING HERE.

- F. 0
G. $\frac{1}{3}$
H. 1
J. 3
K. ∞

47. Yulan will use a bag of 30 solid-colored marbles for a game in which each player randomly draws marbles from the bag. The number of marbles of each color is shown in the table below.

Color	Number
Blue	10
Red	8
Black	6
White	4
Green	2

Yulan will randomly draw 2 marbles from the bag, one after the other, without replacing the first marble. What is the probability that Yulan will draw a black marble first and a green marble second?

- A. $\frac{1}{75}$
B. $\frac{2}{145}$
C. $\frac{4}{15}$
D. $\frac{39}{145}$
E. $\frac{2}{5}$
48. The expression $\frac{2b+c}{b-2c}$ is undefined whenever $b = ?$
- F. $-2c$
G. $-\frac{1}{2}c$
H. 0
J. $\frac{1}{2}c$
K. $2c$



49. What number is halfway between $\frac{2}{5}$ and $\frac{8}{7}$?

- A. $\frac{6}{2}$
- B. $\frac{5}{6}$
- C. $\frac{5}{12}$
- D. $\frac{26}{35}$
- E. $\frac{27}{35}$

DO YOUR FIGURING HERE.

50. A function $f(x)$ is defined as $f(x) = 3^{x^2 - x - 2}$. What 2 real numbers satisfy $f(x) = 1$?

- F. -2 and 2
- G. -2 and 0
- H. -1 and 2
- J. -1 and 0
- K. 0 and 2

51. The ellipse shown in the standard (x,y) coordinate plane below has equation $\frac{(x-3)^2}{9} + \frac{(y-5)^2}{25} = 1$. Which of the following ordered pairs are the foci of the ellipse?

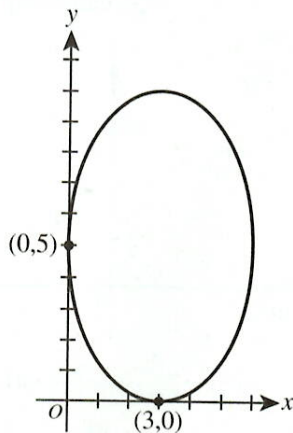

- A. (0,5) and (3, 5)
- B. (3,0) and (3, 9)
- C. (3,0) and (3,10)
- D. (3,1) and (3, 9)
- E. (3,5) and (6, 5)



52. A basket contains 10 solid-colored balls—2 blue, 3 red, and 5 green. Each ball has a single number printed on it. The blue balls are numbered 1 and 2 (each number is used once), the red balls are numbered 1–3 (each number is used once), and the green balls are numbered 1–5 (each number is used once). A ball will be drawn at random from the basket. What is the probability that the ball that is drawn will be red *or* have a 3 printed on it?

- F. $\frac{1}{10}$
 G. $\frac{2}{10}$
 H. $\frac{3}{10}$
 J. $\frac{4}{10}$
 K. $\frac{5}{10}$

53. In the figure below, the given side lengths of $\triangle ABC$ are in inches. What is the area, in square inches, of $\triangle ABC$?

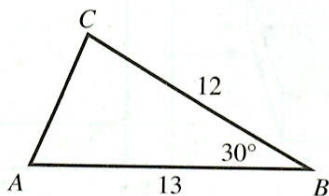

- A. 30
 B. 39
 C. $39\sqrt{3}$
 D. 60
 E. 78
54. There are 66 calories in 15 grams of grated Parmesan cheese, and 59% of those calories are from fat. When measuring Parmesan cheese, 5 grams is equal to 1 tablespoon. Which of the following is closest to the number of calories from fat per tablespoon of grated Parmesan cheese?
- F. 3
 G. 8
 H. 9
 J. 13
 K. 22

DO YOUR FIGURING HERE.





55. In the diagram below, B , F , and H are on \overline{AC} , \overline{AE} , and \overline{BF} , respectively, and $\overline{GH} \perp \overline{BF}$. The area of square $ABGF$ is $\frac{1}{4}$ the area of square $ACDE$. What percent of the area of $ACDE$ does the shaded portion represent?

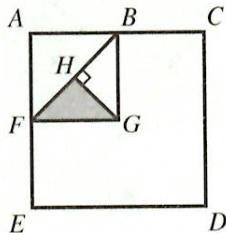

- A. 0.0625%
 B. 0.125%
 C. 0.25%
 D. 6.25%
 E. 12.5%

56. In a data set of 10 distinct values, the single largest value is replaced with a much greater value to form a new data set. Which of the following statements is true about the values of the mean and median for the new data set as compared to the mean and median of the original data set?

- F. The mean will increase; the median will stay the same.
 G. The mean will stay the same; the median will increase.
 H. The mean and median will both stay the same.
 J. The mean and median will both increase.
 K. Using the given information, the means and medians of the 2 data sets cannot be compared.

57. Valley High School and Mountain High School have decided that selected students will attend a daytime theatrical performance that costs \$5 for each teacher and \$3 for each student. One teacher and 10 students from Valley High will attend, and 2 teachers and 25 students from Mountain High will attend. Which of the following matrix products represents the ticket costs, in dollars, for each high school?

- A. $[5 \ 3] \begin{bmatrix} 1 & 2 \\ 10 & 25 \end{bmatrix}$
 B. $[5 \ 3] \begin{bmatrix} 1 & 10 \\ 25 & 2 \end{bmatrix}$
 C. $[5 \ 3] \begin{bmatrix} 1 & 25 \\ 2 & 10 \end{bmatrix}$
 D. $\begin{bmatrix} 5 \\ 3 \end{bmatrix} \begin{bmatrix} 1 & 2 \\ 10 & 25 \end{bmatrix}$
 E. $\begin{bmatrix} 5 \\ 3 \end{bmatrix} \begin{bmatrix} 1 & 10 \\ 2 & 25 \end{bmatrix}$

DO YOUR FIGURING HERE.



58. Karie is inventing a new notation in math. She has decided to use $n\downarrow$ to denote the sum of the first n positive integers. For example, $5\downarrow$ means $5 + 4 + 3 + 2 + 1$. Karie has written 3 statements that she is investigating as possible properties of $n\downarrow$.

- I. $n\downarrow + (n + 1) = (n + 1)\downarrow$
 II. $n\downarrow + n\downarrow = (2n)\downarrow$
 III. $(n^2)\downarrow = (n\downarrow)^2$

Which of these statements, if any, is(are) true for all positive integers n ?

- F. I only
 G. II only
 H. III only
 J. I, II, and III
 K. None
59. Rey wants to make an open box as shown below, using a square piece of cardboard. He intends to cut a 2-inch square from each corner of the cardboard and fold the cardboard along the lines shown to form the sides. The resulting box will have a volume of 72 cubic inches. What are the dimensions, in inches, of the original piece of cardboard?

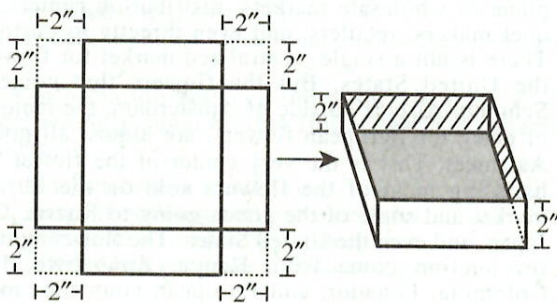

- A. 6×6
 B. 7×7
 C. 8×8
 D. 9×9
 E. 10×10
60. Which of the following quadratic equations has the complex number $(1 + \sqrt{-1})$ as a solution?
- F. $x^2 + 1 = 0$
 G. $x^2 + x + 1 = 0$
 H. $x^2 - x + 1 = 0$
 J. $x^2 + 2x - 2 = 0$
 K. $x^2 - 2x + 2 = 0$

DO YOUR FIGURING HERE.

END OF TEST 2

**STOP! DO NOT TURN THE PAGE UNTIL TOLD TO DO SO.
 DO NOT RETURN TO THE PREVIOUS TEST.**

READING TEST

35 Minutes—40 Questions

DIRECTIONS: There are several passages in this test. Each passage is accompanied by several questions. After reading a passage, choose the best answer to each question and fill in the corresponding oval on your answer document. You may refer to the passages as often as necessary.

Passage I

LITERARY NARRATIVE: This passage is adapted from the book *Flower Confidential* by Amy Stewart (©2007 by Amy Stewart).

"Holland" and "the Netherlands" refer to the same country.

I woke up at 5 a.m. and stared at the ceiling of my Amsterdam hotel room. Outside, the canal boats, which were rented to rowdy college students, had just gone quiet. This was a city of late risers. I got dressed and
5 walked gingerly through the lobby, not wanting to wake the innkeeper who slept on the ground floor, and stepped into the dark, empty streets. The fact is that if you want to go see someone in the flower trade, this is the hour at which you must rise. Even then, when you
10 finally show up at 6 or 7 a.m., blinking in the sudden daylight and trying to remember why you scheduled the meeting in the first place, the person you've gone to meet will look impatient, as though half the day is wasted already.

15 I was on my way to Aalsmeer to see the famous Dutch flower auction. It's known around the world as a remarkably high-tech, high-speed way to sell flowers, but it had modest beginnings: In a café outside of Amsterdam in 1911 some growers came up with the idea of
20 holding an auction to give them more control over how their flowers were priced and sold. They called their auction Bloemenlust. It was not long before a competing auction sprang up nearby—the history of flower markets everywhere is that as soon as there is one, there
25 are two—and each day as the auctions ended, flowers were piled onto bicycles and boats to be delivered along Holland's narrow canals and even narrower streets. This arrangement continued until 1968, the two auctions thriving nearly side by side, until they finally merged
30 and became what is known today as Bloemenveiling Aalsmeer, the largest of a handful of major flower auctions going on year-round in the Netherlands.

35 The bus to Aalsmeer took me through the shuttered streets of Amsterdam and headed south, past the airport. The world seemed to be coming to life at last, and on the road we passed dozens of trucks—some of them plastered with the same grower and wholesaler logos you'd see in Miami—carrying flowers to and
40 after it leaves the grower and before it settles into a

vase on someone's hall table, is remarkable for both its duration and its complexity. A flower can spend a week making its way through a maze of warehouses, airports, auctions, and wholesale markets, and it will emerge
45 from this exhausting journey looking almost as fresh as the day it was picked.

The existence of this auction highlights one major difference between flowers destined for the European market and those sold in the United States. The flowers
50 that I saw arriving in Miami were headed in every direction at once: they were going by truck, rail, and plane to wholesale markets, distribution centers, bouquet makers, retailers, and even directly to customers. There is not a single, centralized market for flowers in
55 the United States. But the flowers that come into Schiphol Airport outside of Amsterdam, the major port of entry for European flowers, are almost all going to Aalsmeer. This is the very center of the flower trade, handling most of the flowers sold on the European
60 market and some of the goods going to Russia, China, Japan, and even the United States. The flowers going up for auction come from Kenya, Zimbabwe, Israel, Colombia, Ecuador, and European countries, making this a sort of global stopping-off point for most of the
65 industry. Every flower market around the world watches the Dutch auction, which acts as a sort of engine for the trade, setting prices and standards worldwide. If you want to follow a flower to market, you'll end up here eventually.

70 By the time the bus pulled into the large circular driveway at the public entrance to the auction, the day really was half over. Flowers and plants had been arriving since midnight, and bidding started before dawn. I stepped off the bus into a kind of floral rush hour:
75 trucks roaring past, people racing from one end of the complex to another, the morning sun glaring down. This place is a behemoth in the small town of Aalsmeer. It employs ten thousand people in a town of just twenty thousand and occupies almost 450 acres, an area larger
80 than Walt Disney World's Magic Kingdom and Epcot theme parks combined. In fact, the auction is like a city in itself, one that runs twenty-four hours a day. All the major growers and wholesalers keep an office, and maybe a warehouse and a loading dock, at Aalsmeer. A
85 full 20 percent of the cut flowers in the world are sold at this very spot, and about half of the world's cut-flower supply moves through the Dutch auction system.

1. Which of the following events referred to in the passage happened first chronologically?
 - A. The author woke up at 5:00 a.m.
 - B. The students on the canal boats quieted down.
 - C. The author's bus passed the Amsterdam airport.
 - D. Flowers and plants started arriving at the auction.
2. The main idea of the first paragraph is that:
 - F. the author is not accustomed to getting up very early in the morning.
 - G. the author is surprised by how quiet Amsterdam is early in the morning.
 - H. though Amsterdam in general is made up of late risers, the local flower trade is busiest in early morning.
 - J. because Amsterdam is usually bustling with activity, it is advisable to meet with people in the local flower trade early in the morning.
3. The author most strongly suggests that when meeting with a person in the flower trade in the morning, that person will look impatient because:
 - A. people in the flower trade are generally late risers.
 - B. he or she is anxious about wasting time.
 - C. he or she can't remember why the meeting was scheduled in the first place.
 - D. people living in Amsterdam are always on the go.
4. The information between the dashes in lines 23–25 most strongly suggests that flower markets generally tend to:
 - F. function best in small cities.
 - G. merge if both markets are successful.
 - H. operate in a competitive atmosphere.
 - J. suffer when competing vendors appear.
5. Based on the author's discussion of the "exhausting journey" (line 45) experienced by flowers sent to auction, the author would most likely agree with the idea that these flowers:
 - A. are surprisingly resilient.
 - B. are picked past their prime.
 - C. have remarkably complex biological needs.
 - D. should be shipped by plane to remain fresh.
6. Based on the passage, the main way the US flower market differs from the European flower market is that:
 - F. flowers in the United States are usually shipped directly to customers.
 - G. flowers in the United States are transported by truck, rail, and plane.
 - H. there are no wholesale flower markets in the United States.
 - J. there is no centralized flower market in the United States.
7. As it is used in line 18, the word *modest* most nearly means:
 - A. bashful.
 - B. simple.
 - C. middling.
 - D. decent.
8. Details in the third paragraph (lines 33–46) indicate that one similarity between the flower industry in the United States and the flower industry in Holland is that both:
 - F. have well-known high-tech flower auctions.
 - G. are supplied primarily by growers in Europe.
 - H. conduct major flower auctions all year long.
 - J. use some of the same growers and wholesalers.
9. The author refers to the Magic Kingdom and Epcot theme parks mainly to:
 - A. indicate that the Aalsmeer market is more crowded than the two theme parks combined.
 - B. provide support for the idea that the Aalsmeer market is a lot of fun to attend.
 - C. suggest that the Aalsmeer market employs as many people as the two theme parks do.
 - D. help emphasize the sprawling space the Aalsmeer market occupies.
10. According to the passage, which of the following numbers of flowers is sold at the Aalsmeer auction?
 - F. Ten thousand flowers per day
 - G. Half of the flowers grown in Holland
 - H. Twenty percent of the world's cut flowers
 - J. Eighty percent of the flowers in the European market

Passage II

SOCIAL SCIENCE: This passage is adapted from the article “The Reluctant President” by Ron Chernow (©2011 by Ron Chernow).

On February 4, 1789, the 69 members of the Electoral College made George Washington the only president to be unanimously elected, but Congress was unable to meet until April to make the choice official.

The Congressional delay in certifying George Washington’s election as president only allowed more time for his doubts to fester as he considered the herculean task ahead. He savored his wait as a welcome “reprieve,” he told his former comrade in arms and future Secretary of War Henry Knox, adding that his “movements to the chair of government will be accompanied with feelings not unlike those of a culprit who is going to the place of his execution.” His “peaceful abode” at Mount Vernon, his fears that he lacked the requisite skills for the presidency, the “ocean of difficulties” facing the country—all gave him pause on the eve of his momentous trip to New York. In a letter to his friend Edward Rutledge, he claimed that, in accepting the presidency, he had given up “all expectations of private happiness in this world.”

The day after Congress counted the electoral votes, declaring Washington the first president, it dispatched Charles Thomson, the secretary of Congress, to bear the official announcement to Mount Vernon. The legislators had chosen a fine emissary. A well-rounded man, known for his work in astronomy and mathematics, the Irish-born Thomson couldn’t have relished the trying journey to Virginia, which was “much impeded by tempestuous weather, bad roads, and the many large rivers I had to cross.” Yet he rejoiced that the new president would be Washington, whom he venerated as someone singled out by Providence to be “the savior and father” of the country. Having known Thomson since the Continental Congress, Washington esteemed him as a faithful public servant and exemplary patriot.

Around noon on April 14, 1789, Washington flung open the door at Mount Vernon and greeted his visitor with a cordial embrace. Once in the privacy of the mansion, he and Thomson conducted a stiff verbal minuet, each man reading from a prepared statement. Thomson began by declaring, “I am honored with the commands of the Senate to wait upon your Excellency with the information of your being elected to the office of President of the United States of America” by a unanimous vote. He read aloud a letter from Senator John Langdon of New Hampshire, the president pro tempore. “Suffer me, sir, to indulge the hope that so auspicious a mark of public confidence will meet your approbation and be considered as a sure pledge of the affection and support you are to expect from a free and enlightened people.” There was something deferential, even slightly servile, in Langdon’s tone, as if he feared that Washington might renege on his promise and refuse to take the job. Thus was greatness once again thrust upon George Washington.

Any student of Washington’s life might have predicted that he would acknowledge his election in a short, self-effacing speech full of disclaimers. “While I realize the arduous nature of the task which is conferred on me and feel my inability to perform it,” he replied to Thomson, “I wish there may not be reason for regretting the choice. All I can promise is only that which can be accomplished by an honest zeal.” This sentiment of modesty jibed so perfectly with Washington’s private letters that it could not have been feigned: he wondered whether he was fit for the post, so unlike anything he had ever done. The hopes for republican government, he knew, rested in his hands. As commander in chief of the Continental Army, he had been able to wrap himself in a self-protective silence, but the presidency would leave him with no place to hide and expose him to public censure as nothing before.

Because the vote counting had been long delayed, Washington, 57, felt the crush of upcoming public business and decided to set out promptly for New York on April 16, accompanied in his elegant carriage by Thomson and aide David Humphreys. His diary entry conveys a sense of foreboding: “About ten o’clock, I bade adieu to Mount Vernon, to private life, and to domestic felicity and, with a mind oppressed with more anxious and painful sensations than I have words to express, set out for New York . . . with the best dispositions to render service to my country in obedience to its call, but with less hope of answering its expectations.” Waving goodbye was Martha Washington, who wouldn’t join him until mid-May. She watched her husband of 30 years depart with a mixture of bittersweet sensations, wondering “when or whether he will ever come home again.” She had long doubted the wisdom of this final act in his public life. “I think it was much too late for him to go into public life again,” she told her nephew, “but it was not to be avoided.”

11. Which of the following statements best captures the broad, general message of the passage?
- The most effective leader pairs strong inner confidence with public displays of humility.
 - Leaving a comfortable, familiar life for the unknown will likely have great rewards.
 - Even a leader who is strongly supported by the public may have deep, private insecurities.
 - Electing someone who is not prepared to lead may have dangerous consequences.

12. One function in the passage of including information about Mount Vernon and Martha Washington is to create a contrast between George Washington's:
- F. carefree, casual demeanor around his family and his stern aspect with advisors and aides.
 - G. idyllic, established home life and the uncertainty of what was to come in his public life.
 - H. restlessness at home and his calm, collected sense of industriousness as president.
 - J. enjoyment of a private home life and his dislike of working without close advisors in government.
13. As it is used in line 35, the phrase "stiff verbal minuet" refers to the interaction between George Washington and Thomson as Washington:
- A. writes a letter to Langdon, the president pro tempore.
 - B. excuses himself from Thomson so that he may say goodbye to his wife, Martha.
 - C. is officially told that he has been elected president of the United States and accepts the position.
 - D. formally resigns from his position as commander in chief of the army and appoints a replacement.
14. The passage author argues that the letter read to George Washington on April 14, 1789, suggests Langdon's concern that:
- F. Washington would be forced by Congress to confer his duties to a president pro tempore for several months.
 - G. Washington had been behaving inappropriately as commander in chief of the army.
 - H. the problems facing the country were insurmountable for any new president.
 - J. there was a chance that Washington would reject the opportunity to become president.
15. The passage characterizes which of the following people as expressing a subtle acknowledgement of George Washington's burden?
- A. Knox
 - B. Langdon
 - C. Rutledge
 - D. Thomson
16. According to the passage, the congressional delay in certifying George Washington's election allowed Washington time to:
- F. steep himself in his doubts and fears, causing them to grow.
 - G. share with others his hopes for and confidence in the republican government.
 - H. closely consider the herculean task ahead, which eased some of his worry.
 - J. confer with his aides about the difficulties facing the country.
17. The passage indicates that Thomson's journey to Mount Vernon was made difficult by:
- A. the lack of a party to accompany him, which left him vulnerable to bandits.
 - B. his need to return as quickly as possible to his duties as the secretary of Congress.
 - C. terrible weather and a route that included river crossings and bad roads.
 - D. his miscalculation of the route, which led to a long, arduous detour.
18. As it is used in line 43, the word *mark* most nearly means:
- F. boundary.
 - G. sign.
 - H. impact.
 - J. stain.
19. The passage most strongly implies that while Washington was commander in chief of the army, one way he had preserved his good reputation was by:
- A. giving speeches.
 - B. publishing pamphlets.
 - C. writing letters.
 - D. remaining silent.
20. The passage author makes clear Martha Washington's view that her husband's return to public life was:
- F. an inevitable event for him.
 - G. a subtle rejection of his private life with her.
 - H. an inexcusable decision for him.
 - J. a source of pride for her.

Passage III

HUMANITIES: Passage A is adapted from the article “A Million Little Pieces” by Andrea K. Scott (©2012 by Condé Nast Publications). Passage B is adapted from the article “Everything in Its Right Place” by Karen Rosenberg (©2011 by The New York Times).

Passage A by Andrea K. Scott

The artist Sarah Sze stood in the foyer on the second floor of the Asia Society, on the Upper East Side, amid dozens of crates, plastic storage bins, plastic tubs, and plastic bags. It was a late afternoon in December, and she and six assistants were completing the installation of eight new sculptures. The process was so labor-intensive that it had taken more than three weeks.

Sze arranges everyday objects into sculptural installations of astonishing intricacy. She joins things manufactured to help build other things (ladders, levels, winches, extension cords) with hundreds of commonplace items (cotton swabs, push-pins, birthday candles, aspirin tablets), creating elaborate compositions that extend from gallery walls, creep into corners, and surge toward ceilings. Duchamp paved the way for Sze’s work when he made a sculpture by mounting a bicycle wheel on a wooden stool. But her virtuosic creations are equally indebted to the explosive energy of Bernini’s Baroque masterpiece “The Ecstasy of St. Teresa,” a marble statue that seems to ripple with movement.

Sze’s show was about the relationships between landscape and architecture, and sculpture and line. She walked from the foyer into the galleries, and stood by a floor-to-ceiling window that had been concealed by a wall for a decade—the museum had uncovered it at her request. She began to confer with her studio manager, Mike Barnett. Sze was wondering about a branch that she had placed in the installation by the window, after pruning it from her roof-top garden, in downtown Manhattan. It rose from the floor like a sapling emerging from a crack in the sidewalk. Twilight had turned the window into a mirror, but in daylight the branch would compete with a view of Park Avenue median greenery, traffic, and apartment buildings.

“There’s a nighttime view and a daytime view,” she said to Barnett. “I want that to be a plus, not a minus. Is this getting lost?”

Barnett said, “I think it works.”

There was a pause so long that it should have been awkward. Sze finally said, “Even if it’s a loose end, that could be interesting. I like that it looks like a fragment—like it could just drift away.”

Passage B by Karen Rosenberg

“Infinite Line,” Sarah Sze’s midcareer solo show at Asia Society Museum, promised a new angle on Ms. Sze’s mesmerizing, minutely detailed installations. And it delivers one, though the art—much of it made for the occasion—doesn’t always rise to the challenge.

The show makes the case that Ms. Sze, who is Chinese-American, has been profoundly influenced by many forms of Asian art. It also emphasizes her drawings, which have rarely been exhibited, and encourages you to see her three-dimensional artworks as drawings in space.

Implicitly, it de-emphasizes the prosaic nature of her art materials: the cotton swabs, toothpicks, bottle caps and other throwaway objects that she fashions, with gee-whiz structural ingenuity, into rambling landscapes and galactic spirals. Over the years viewers (myself included) have had a tendency to focus on all of this stuff—to see Ms. Sze’s art as embodying a quintessentially American consumerism.

“Infinite Line” presents a more nuanced, intellectual and worldly artist: one who talks about space like an architect and vision like an ophthalmologist, who rhapsodizes about the shifting perspective in Chinese painting and makes her own Asian-inspired drawings on long scrolls of paper.

But while Ms. Sze says some fascinating things in a catalog interview, she’s not at her best in these galleries. Nothing here is quite up to the level of her solo at the Tanya Bonakdar Gallery last year, which used cantilevered shelves laden with rocks, plants and office supplies to evoke a topsy-turvy green house or curiosity cabinet.

That’s especially true of the works on paper, which are installed in a separate room and look physically and spiritually cut off from Ms. Sze’s signature installations. Most of them find her in doodle mode, drawing clusters of architecture and tiny figures that can be expanded or contracted to suit any scale or purpose.

Pure drawing, as a medium, does not seem to excite Ms. Sze. It takes a hint of found objects, or a flirtation with the third dimension, to bring out her imagination, as in the collage “Guggenheim as a Ruin,” which envisions a crumbling, entropic version of that museum, or the pop-up drawing “Notepad,” whose laser-cut and folded pages form a series of cascading fire escapes.

Questions 21–25 ask about Passage A.

21. In Passage A, the first paragraph (lines 1–7) functions mainly to emphasize the:
- A. leadership skills Sze demonstrated in relegating work to her assistants at the Asia Society.
 - B. ingenuity and problem solving Sze used to create her eight sculptures at the Asia Society.
 - C. amount of time and materials Sze needed to create her eight sculptures at the Asia Society.
 - D. amount of space Sze’s eight sculptures took up on the second floor of the Asia Society.
22. Which of the following sculptural installations would be most conceptually similar to Sze’s sculptural installations discussed in the second paragraph of Passage A (lines 8–21)?
- F. An oversized tricycle hanging above a sofa
 - G. A large slab of marble with streams of water rippling over it
 - H. Rubber bands and nails joined together to form a network of cables
 - J. Paper clips strewn about randomly on a gallery floor
23. As it is used in line 13, the word *elaborate* most nearly means:
- A. luxurious.
 - B. exact.
 - C. overdone.
 - D. complicated.
24. It can most reasonably be inferred from Passage A that the main reason Sze requested that the floor-to-ceiling window be uncovered is that she wanted the window to contribute to her exploration of the:
- F. relationship between landscape and architecture.
 - G. influences of consumerism on cultural constructs.
 - H. differences between Asian and Western art.
 - J. effects of urban sprawl on the environment.
25. In Passage A, the author most likely references Bernini’s “The Ecstasy of St. Teresa” in order to emphasize that Sze’s installations appear:
- A. antiquated.
 - B. symmetrical.
 - C. ornate.
 - D. lively.

Questions 26 and 27 ask about Passage B.

26. The author of Passage B is most critical of which artworks in Sze’s show “Infinite Line”?
- F. Two-dimensional works on paper
 - G. Three-dimensional works on paper
 - H. Sculptural installations
 - J. Collages
27. As it is used in line 57, the word *fashions* most nearly means:
- A. accommodates.
 - B. initiates.
 - C. combines.
 - D. wears.

Questions 28–30 ask about both passages.

28. Which of the following statements best captures a difference in the purposes of the passages?
- F. Passage A provides a critique of how Sze conceptualizes her art shows, while Passage B provides a comparison between Sze and other Asian American artists.
 - G. Passage A provides a glimpse into Sze’s creative process, while Passage B provides a critique of her art show “Infinite Line.”
 - H. Passage A provides a comparison of Sze’s personal and public personas, while Passage B provides a narrative concerning how Sze discovered Asian art.
 - J. Passage A provides an overview of Sze’s development as an artist, while Passage B provides an interpretation of Sze’s artwork.
29. Compared to Passage B, Passage A provides more information regarding how Sze:
- A. places objects within a gallery space.
 - B. feels about the artists Duchamp and Bernini.
 - C. reacts to critical interpretations of her artwork.
 - D. incorporates classical Chinese imagery into her sculptural installations.
30. The authors of Passage A and Passage B both praise Sze for her use of:
- F. organic material in her collages.
 - G. detail in her sculptural installations.
 - H. proportion in her works on paper.
 - J. natural light in her sculpture gardens.

Passage IV

NATURAL SCIENCE: This passage is adapted from the article "The Strangest Bird" by R. Ewan Fordyce and Daniel T. Ksepka (©2012 by Scientific American).

That the earliest penguins have turned up in New Zealand is probably no coincidence. Until humans arrived, less than 1,000 years ago, the islands there formed a temperate seabird paradise on the margins of the South Pacific and Southern oceans. The region was free of terrestrial predatory mammals and afforded space for breeding colonies, with abundant food in the surrounding seas.

Geologic evidence suggests that the area would have been equally conducive to the seabird way of life at the end of the Cretaceous. New Zealand today is the largest exposed area of a submerged mini continent known as Zealandia that broke off from the ancient supercontinent of Gondwana perhaps 85 million years ago. Thus liberated, Zealandia drifted northeast into the Pacific, carrying plants and animals, including dinosaurs, to its resting spot about halfway between the South Pole and tropics. As Zealandia drifted, it cooled and sank. Shallow seas flooded the land, and a broad continental shelf formed around its perimeter. Despite its isolation from other landmasses, Zealandia did not emerge from the end-Cretaceous extinction unscathed. Many of its marine and terrestrial organisms perished in that die-off. Yet what was bad for those creatures was good for penguins. With marine reptiles such as mosasaurs and plesiosaurs out of the picture, early penguins could swim the waters around Zealandia free of competition or predation.

Having gotten their sea legs in Zealandia, penguins soon expanded their domain dramatically, dispersing across thousands of miles and into new climate zones. Fossils of *Perudyptes devriesi* from Peru show that penguins arrived close to the equator about 42 million years ago, settling in one of the hottest places on earth during one of the hottest times in the planet's history. By 37 million years ago the birds had spread to almost every major landmass in the Southern Hemisphere.

Yet why, after restricting themselves to Zealandia for millions of years, did penguins suddenly start spreading across the Southern Hemisphere around 50 million years ago? Recently Daniel T. Ksepka discovered an important clue to this mystery: a long-overlooked feature on the surface of fossil flipper bones. The humerus bears a series of grooves that are easy to miss among the markings associated with tendons and muscles.

Those grooves form at the spot where a cluster of arteries and veins presses against the humerus. These blood vessels make up a countercurrent heat exchanger called the humeral arterial plexus, which allows penguins to limit heat loss through the flippers and to maintain their core body temperature in cold water. In

live penguins, hot blood leaving the heart gets cooled by the plexus before reaching the flipper tip, and cold blood returning from the flipper gets warmed before approaching the heart.

The identity of the grooves on the fossil flipper bones shed some surprising light on the origin of penguin thermoregulation. One of the most amazing aspects of modern penguin biology is the birds' ability to tolerate extreme cold. One would logically assume that the plexus evolved as an adaptation to frigid environments. But fossils suggest otherwise. Penguins such as the *Delphinornis* from Antarctica show that this feature evolved at least 49 million years ago. The early *Waimanu* penguins from Zealandia show no hint of the trait at 58 million years ago, however. The plexus therefore must have evolved in the intervening time, when the earth was far warmer than it is today. Back then, Antarctica lacked permanent ice sheets and instead offered a temperate forested environment; Zealandia was even toastier.

What use did early penguins have for a heat-conserving plexus in this greenhouse world? Although sea-surface temperatures were high, early penguins probably foraged in cool upwelling regions, which are rich in nutrients and thus support a bounty of prey, including fish and squid. But because heat is lost more quickly in water than air, a warm-blooded animal such as the penguin risks going into hypothermia even in warm seas if the water is below core body temperature. Reducing heat loss through the flipper would have helped them conserve body heat on long foraging swims in chilly waters.

The humeral plexus may have also allowed penguins to survive the long open-water journeys by which they initially dispersed from Zealandia to other continents. Only much later would modern penguins co-opt this mechanism to invade the sea ice shelves that formed when the planet cooled.

31. One main purpose of the passage is to:
- analyze why New Zealand has long been an ideal environment for penguins.
 - compare two leading theories about penguin habitats based on evidence from the fossil record.
 - present evidence that penguin populations have steadily declined since the late Cretaceous.
 - describe a particular fossil discovery that led to a better understanding of how penguins evolved.

32. Which of the following statements best summarizes the authors' claim about the relationship between the humeral arterial plexus and cold environments?
- F. The early emergence of the humeral arterial plexus allowed penguins to later inhabit cold environments.
 - G. The humeral arterial plexus appears to have little to do with penguins' ability to survive in cold environments.
 - H. The humeral arterial plexus allows penguins to survive in cold environments by increasing penguins' heart rates.
 - J. Once penguins adapted to the sea ice shelves that formed when the planet cooled, they no longer had a need for the humeral arterial plexus.
33. It can reasonably be inferred from the passage that the phrase "what was bad for those creatures" (line 24) refers to:
- A. a change in food sources for early penguins.
 - B. the end-Cretaceous die-off of the dinosaurs and other animals.
 - C. how Zealandia's isolation from the South Pole affected Zealandia's terrestrial mammals.
 - D. seabirds' exposure to new climate zones.
34. According to the passage, about 55 million years ago, how did the average temperatures of Zealandia compare to those of Antarctica?
- F. Zealandia was generally cooler than Antarctica.
 - G. Zealandia was generally warmer than Antarctica.
 - H. Temperatures in Zealandia were about the same as those in Antarctica.
 - J. Temperatures in Zealandia were higher than Antarctica in the summer and lower in the winter.
35. In the passage, the authors conclude that the humeral arterial plexus mechanism emerged in penguins in conjunction with a need to:
- A. survive in new climates closer to the equator.
 - B. adapt to a temperate forested environment.
 - C. forage in cool upwelling regions of the sea.
 - D. swim long distances on warm ocean surfaces.
36. According to the passage, which of the following occurred as Zealandia drifted into the Pacific?
- F. A broad continental shelf formed around Gondwana, making Zealandia more isolated.
 - G. Gondwana warmed, becoming a seabird paradise.
 - H. Zealandia slowly became completely submerged.
 - J. Zealandia's climate cooled and the landmass sank lower in the seas.
37. The passage indicates that penguins living in the Cretaceous faced predation and competition for food from:
- A. marine reptiles.
 - B. large fish.
 - C. other seabird species.
 - D. squid.
38. Based on the passage, which penguin fossil bones yielded the most significant information for the authors' study of penguins?
- F. Feet
 - G. Chest
 - H. Flippers
 - J. Skull
39. As it is used in line 45, the word *bears* most nearly means:
- A. produces.
 - B. endures.
 - C. exhibits.
 - D. merits.
40. The passage most strongly suggests that the markings from the humeral plexus had likely gone unnoticed on fossils because:
- F. modern penguin bones do not have such markings.
 - G. the markings are difficult to distinguish from others on the humerus.
 - H. the markings easily deteriorate over time.
 - J. little scientific research has been devoted to early penguin fossils.

END OF TEST 3

**STOP! DO NOT TURN THE PAGE UNTIL TOLD TO DO SO.
DO NOT RETURN TO A PREVIOUS TEST.**



SCIENCE TEST

35 Minutes—40 Questions

DIRECTIONS: There are several passages in this test. Each passage is followed by several questions. After reading a passage, choose the best answer to each question and fill in the corresponding oval on your answer document. You may refer to the passages as often as necessary.

You are NOT permitted to use a calculator on this test.

Passage I

Wood mice (a species of mammal) typically forage for food at night. Their foraging behavior can be affected by environmental factors, including the presence of moonlight and the presence of shelter (such as shrubs). Four students each proposed a hypothesis describing how the foraging behavior of wood mice is affected by the presence of moonlight and shelter. Then they conducted an experiment to test their hypotheses.

Student 1

Wood mice are more likely to forage when moonlight is absent than when moonlight is present. The absence of moonlight decreases the chance that a wood mouse will be captured by a predator. Therefore, the number of wood mouse visits to a foraging site will be greater during the new moon than during the full moon. Shelter has no effect on foraging behavior.

Student 2

Wood mice are more likely to forage at sites with shelter than at sites without shelter. The presence of shelter decreases the chance that a wood mouse will be captured by a predator. Therefore, the number of wood mouse visits to a foraging site will be greater when shelter is present than when shelter is absent. Moonlight has no effect on foraging behavior.

Student 3

Wood mice are more likely to forage at sites with shelter than at sites without shelter, and they are more likely to forage when moonlight is absent than when moonlight is present. Both the presence of shelter and the absence of moonlight decrease the chance that a wood mouse will be captured by a predator. Therefore, the greatest number of wood mouse visits will be to foraging sites with shelter during the new moon.

Student 4

The foraging behavior of wood mice is not affected by the presence of shelter or moonlight. These factors do not affect the chance that a wood mouse will be captured by a predator, and therefore do not affect the number of wood mouse visits to a foraging site.

Experiment

Over the course of several months, the students counted the number of wood mouse visits to a foraging site with shelter and a foraging site without shelter during the new moon and during the full moon (see table).

Shelter present?	Number of visits during new moon	Number of visits during full moon
Yes	1,003	882
No	285	191

Table adapted from Ramón Perea et al., "Moonlight and Shelter Cause Differential Seed Selection and Removal by Rodents." ©2011 by The Association for the Study of Animal Behaviour.



1. A scientist claimed that adding shrubs to a foraging site will increase the number of wood mouse visits to that site. This claim is consistent with the hypothesis or hypotheses of which of the students?

A. Student 2 only
 B. Students 1 and 4 only
 C. Students 2 and 3 only
 D. Students 1, 2, 3, and 4

2. Based on Student 3's hypothesis, a wood mouse would be *least* likely to be captured by a predator during the:

F. new moon at a foraging site with shelter.
 G. new moon at a foraging site without shelter.
 H. full moon at a foraging site with shelter.
 J. full moon at a foraging site without shelter.

3. Consider the results of the experiment, during the new moon and during the full moon, for the site without shelter. Are these results consistent with the hypothesis of Student 1?

A. Yes; there were fewer visits during the new moon than during the full moon.
 B. Yes; there were more visits during the new moon than during the full moon.
 C. No; there were fewer visits during the new moon than during the full moon.
 D. No; there were more visits during the new moon than during the full moon.

4. Before the experiment, which student would most likely have predicted that the number of wood mouse visits would be approximately the same for all the conditions that were tested?

F. Student 1
 G. Student 2
 H. Student 3
 J. Student 4

5. Over the course of several months, a scientist conducted a study to determine if the number of wood mouse visits to a foraging site varied with moonlight brightness. The results of the study are shown in the following figure.

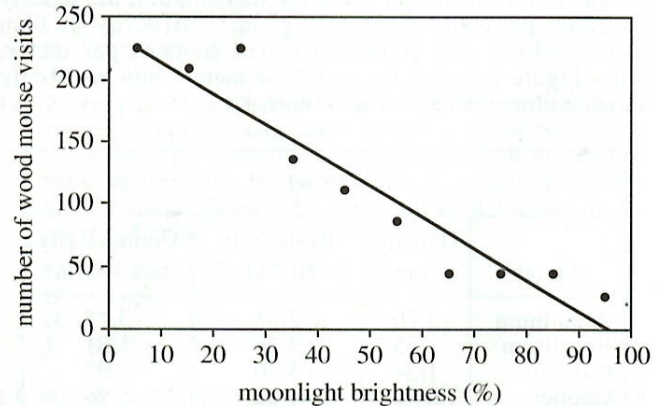

Figure adapted from Ramón Perea et al., "Moonlight and Shelter Cause Differential Seed Selection and Removal by Rodents." ©2011 by The Association for the Study of Animal Behaviour.

These results are consistent with the hypothesis or hypotheses of which of the students?

A. Student 1 only
 B. Student 4 only
 C. Students 1 and 3 only
 D. Students 2 and 3 only

6. The results of the experiment are most consistent with the hypothesis of which student?

F. Student 1
 G. Student 2
 H. Student 3
 J. Student 4

7. Which of the following questions was addressed by each of the hypotheses but cannot be directly answered by the results of the experiment?

A. Does the presence of moonlight and shelter affect the chance that a wood mouse will be captured by a predator?
 B. Does the presence of moonlight and shelter affect the chance that a wood mouse will construct a nest at a foraging site?
 C. Does a foraging site receive more visits from wood mice during a new moon than during a full moon?
 D. Does a foraging site with shelter receive more visits from wood mice than does a foraging site without shelter?

Passage II

Resistivity is the tendency of a material to oppose the flow of an electric current, whereas *conductivity* is the ability of a material to carry an electric current. Table 1 lists, for each of 12 metals at the same temperature, the density (in grams per cubic centimeter, g/cm^3), resistivity (in ohm meters, $\Omega\cdot\text{m}$), and conductivity (in siemens per meter, S/m). Figure 1 shows, for 3 of these metals, how resistivity varies with temperature (in kelvins, K).

Metal	Density (g/cm^3)	Resistivity ($\times 10^{-8} \Omega\cdot\text{m}$)	Conductivity ($\times 10^7 \text{ S}/\text{m}$)
Aluminum	2.70	2.65	3.77
Beryllium	1.85	3.56	2.81
Calcium	1.54	3.36	2.97
Copper	8.96	1.68	5.96
Gold	19.3	2.21	4.52
Iron	7.87	9.61	1.03
Lithium	0.530	9.28	1.08
Magnesium	1.74	4.39	2.23
Potassium	0.890	7.20	1.39
Silver	10.5	1.59	6.30
Sodium	0.970	4.88	2.05
Tungsten	19.3	5.39	1.86

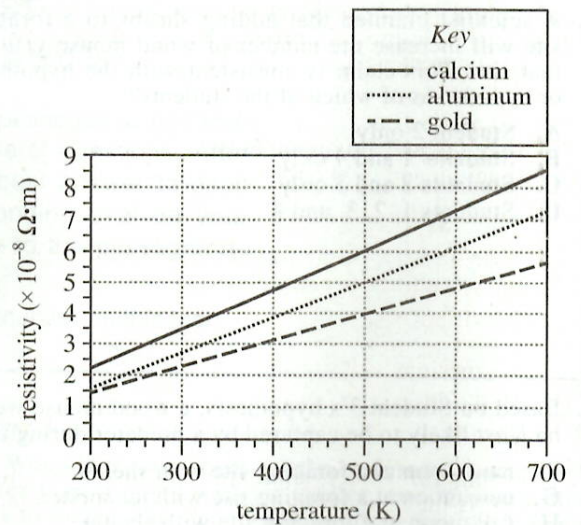

Figure 1

8. According to Figure 1, at a temperature of 600 K, which of calcium, aluminum, and gold has(have) a resistivity greater than $7 \times 10^{-8} \Omega \cdot m$?
- F. Calcium only
 G. Aluminum only
 H. Calcium and aluminum only
 J. Calcium and gold only
9. Based on Table 1, of the following 4 metals, which has the greatest ability to carry electric current?
- A. Beryllium
 B. Iron
 C. Magnesium
 D. Tungsten
10. According to Figure 1, approximately how many times as great is the resistivity of aluminum at 600 K than at 320 K?
- F. $\frac{1}{4}$
 G. $\frac{1}{2}$
 H. 2
 J. 4
11. Suppose that a certain metal has a resistivity of $3.46 \times 10^{-8} \Omega \cdot m$. Based on Table 1, the conductivity of this metal is most likely closest to which of the following?
- A. $1.69 \times 10^{-7} S/m$
 B. $2.89 \times 10^{-7} S/m$
 C. $1.69 \times 10^7 S/m$
 D. $2.89 \times 10^7 S/m$
12. When choosing a suitable metal for use in overhead electrical cables, engineers prefer a metal for which the expression (density) \times (resistivity) has as small a value as possible. Based on Table 1, which of the following metals would be most suitable for use in an overhead cable?
- F. Aluminum
 G. Copper
 H. Gold
 J. Silver
13. Based on Figure 1, the resistivities of the metals listed in Table 1 were most likely measured at a temperature closest to which of the following?
- A. 200 K
 B. 300 K
 C. 400 K
 D. 500 K

Passage III

When *Moina micrura* (microscopic aquatic crustaceans) are exposed to unfavorable environmental conditions, they produce *ephippia* (specialized eggs that each contain a dormant embryo). The embryos remain dormant until the ephippia are exposed to favorable environmental conditions that cause the ephippia to hatch. Two experiments examined how pH and light intensity affect the hatching of *M. micrura* ephippia.

Experiment 1

Each of 15 identical beakers received 50 mL of water and 120 freshly laid *M. micrura* ephippia. The beakers were then equally divided into 5 groups (Groups L–P). For each group of beakers, the water was maintained at 1 of 5 different pH values (see Table 1).

Group	pH
L	3.0
M	5.0
N	7.0
O	9.0
P	11.0

Each beaker was then incubated at 27°C and received 12 hr of light per day at a light intensity of 650 lux. At the end of 7 days, the number of ephippia that had hatched in each beaker was counted, and the average number of ephippia hatched in each group was calculated (see Figure 1).

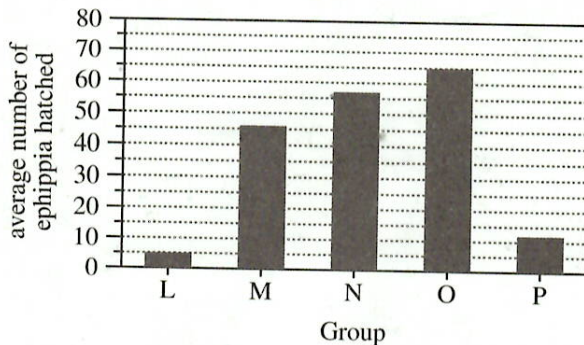

Figure 1

Experiment 2

Each of 20 identical beakers received 50 mL of water and 120 freshly laid *M. micrura* ephippia. The beakers were then equally divided into 5 groups (Groups Q–U). Each beaker was incubated at 25°C, and the water in each beaker was maintained at a pH of 7.0. Group Q was kept in the dark, and each of Groups R–U received 12 hr of light per day at 1 of 4 different light intensities (see Table 2).

Group	Light intensity (lux)
Q	0
R	300
S	650
T	850
U	1,300

At the end of 7 days, the average number of ephippia hatched in each group was determined as in Experiment 1 (see Figure 2).

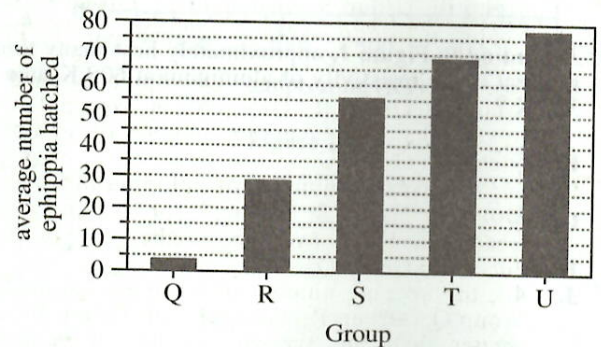

Figure 2

Figures adapted from N. E. T. Rojas, M. A. Marins, and O. Rocha, "The Effect of Abiotic Factors on the Hatching of *Moina micrura* Kurz, 1874 (Crustacea: Cladocera) Ephippial Eggs." ©2001 by the International Institute of Ecology.

14. According to the results of Experiment 2, among the 5 groups tested, as the light intensity increased, the average number of ephippia hatched:
- F. decreased only.
 G. increased only.
 H. decreased and then increased.
 J. increased and then decreased.
15. Suppose that a scientist wants to develop an artificial system for hatching *M. micrura* ephippia in a laboratory environment. Based on the results of Experiment 1, which of the pH values tested would most likely maximize the chances of hatching *M. micrura* ephippia in this system?
- A. 5.0
 B. 7.0
 C. 9.0
 D. 11.0



16. Consider the units of measurement “mL” and “lux” in Experiment 2. Which of the following phrases best describes the quantities represented by those units?
- | <u>mL</u> | <u>lux</u> |
|--------------------|----------------------------|
| F. mass of water | duration of light exposure |
| G. mass of water | light intensity |
| H. volume of water | duration of light exposure |
| J. volume of water | light intensity |
17. Consider the statement “The number of ephippia that hatched, on average, was greater for the ephippia kept in the dark than it was for the ephippia exposed to light.” Do the results of Experiment 2 support this statement?
- A. Yes; the average number of ephippia hatched in Group R, Group S, Group T, or Group U was greater than the average number of ephippia hatched in Group Q.
- B. Yes; the average number of ephippia hatched in Group Q, Group R, Group S, or Group T was greater than the average number of ephippia hatched in Group U.
- C. No; the average number of ephippia hatched in Group R, Group S, Group T, or Group U was greater than the average number of ephippia hatched in Group Q.
- D. No; the average number of ephippia hatched in Group Q, Group R, Group S, or Group T was greater than the average number of ephippia hatched in Group U.
18. Which of the following pieces of equipment was most likely used to collect the data that were averaged to produce Figures 1 and 2?
- F. Electronic balance
G. Light microscope
H. Metric ruler
J. pH meter
19. In Experiment 1, the *total* length of time a group of beakers was exposed to light was:
- A. 12 hr.
B. 24 hr.
C. 84 hr.
D. 168 hr.
20. Consider the claim “The length of time that the beakers in a group were incubated affected the average number of ephippia hatched in the group.” Can this claim be evaluated on the basis of the results of the 2 experiments?
- F. Yes, because incubation time was different for each group.
G. Yes, because incubation time was the same for all the groups.
H. No, because incubation time was different for each group.
J. No, because incubation time was the same for all the groups.

Passage IV

Atmospheres (atm), torr, and kilopascals (kPa) are common units of pressure. Figure 1 can be used to convert between torr and kPa. A pressure of 1 atm is indicated in Figure 1.

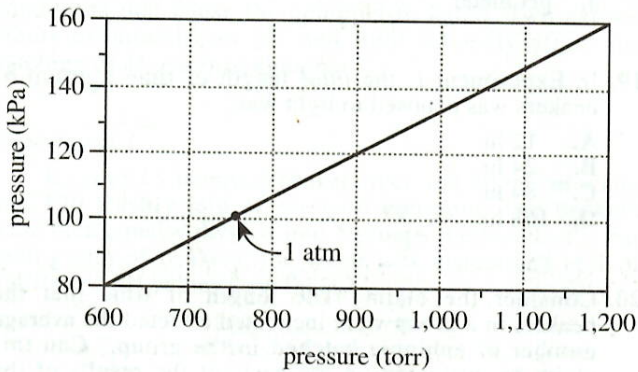

Figure 1

Figure 2 shows how boiling point (BP) varies with atmospheric pressure for 3 compounds: acetaldehyde, acetone, and pentane. The unit of pressure is torr.

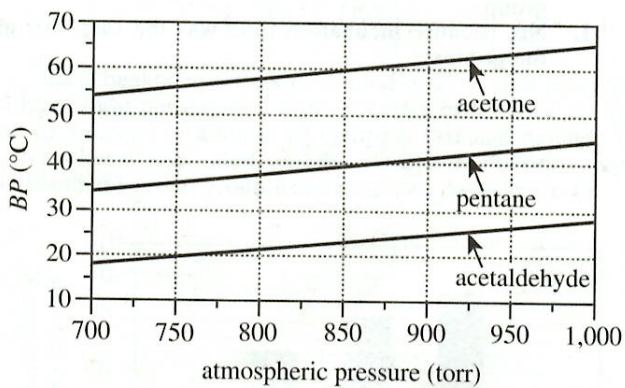

Figure 2

Figure 3 shows how BP varies with atmospheric pressure for 3 other compounds: ethanol, methanol, and methyl acetate. The unit of pressure is kPa.

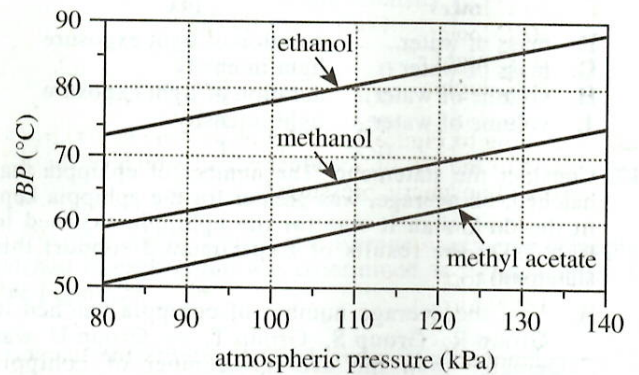
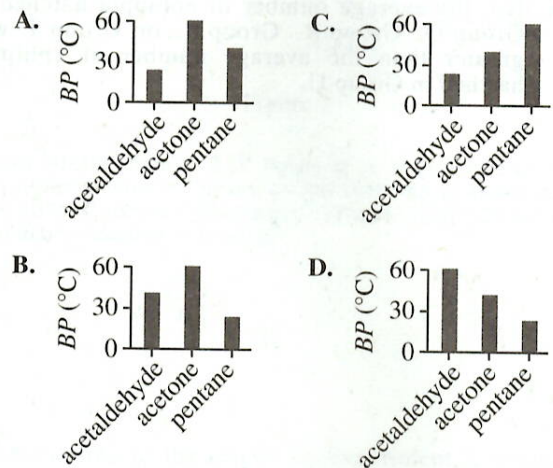

Figure 3

21. According to Figure 2, which of the following graphs best shows the BPs of acetaldehyde, acetone, and pentane at 850 torr?





22. According to Figure 3, at 110 kPa, the *BP* of methyl acetate is approximately how much lower than or higher than the *BP* of ethanol?
- F. 20°C lower
G. 10°C lower
H. 10°C higher
J. 20°C higher
23. According to Figure 2, the *BP* of pentane at 700 torr is closest to the *BP* of acetaldehyde at which of the following atmospheric pressures?
- A. 700 torr
B. 800 torr
C. 900 torr
D. 1,000 torr
24. A compound's *standard boiling point* is the temperature at which the compound boils when the atmospheric pressure is 1 atm. Based on Figures 1 and 2, the standard boiling point of pentane is approximately:
- F. 21°C.
G. 36°C.
H. 57°C.
J. 66°C.
25. Based on Figure 1, a pressure of 2 atm would correspond to a pressure in torr that is:
- A. less than 700 torr.
B. between 700 torr and 950 torr.
C. between 950 torr and 1,200 torr.
D. greater than 1,200 torr.
26. Suppose a sample of methanol is in a chamber maintained at 60°C and 110 kPa. Based on Figure 3, if the temperature is kept constant, which of the following changes in the pressure will cause the sample to boil?
- F. A decrease of 30 kPa
G. A decrease of 20 kPa
H. An increase of 20 kPa
J. An increase of 30 kPa

Passage V

Multivitamin (MV) tablets often contain iron in the form of Fe^{2+} . In aqueous solution, Fe^{2+} does not absorb visible light. However, when *o*-phenanthroline (*o*-phen) is present, it interacts with Fe^{2+} to form an orange-colored complex, which absorbs visible light at a wavelength of 508 nanometers (nm).

Students measured the absorbance at 508 nm—the A_{508} —of 6 solutions having known Fe^{2+} concentrations and then determined the Fe^{2+} content of 4 brands of MV tablets (Brands A–D).

Experiment 1

Steps 1–5 were performed 6 times:

1. A certain volume of an aqueous stock solution having a concentration of 0.04 mg Fe^{2+} /mL was placed in a 100.0 mL flask.
2. Two mL of *hydroquinone* solution was added to the flask to stabilize Fe^{2+} .
3. Three mL of *o*-phen solution was added to the flask.
4. The contents of the flask were diluted with H_2O to form a solution of 100.0 mL.
5. The A_{508} of the solution formed was measured with a colorimeter.

Table 1 shows, for each of the 6 solutions formed (Solutions 1–6), the volume of stock solution used, the Fe^{2+} concentration, and the A_{508} .

Solution	Volume of stock solution (mL)	Fe^{2+} concentration (mg/mL)	A_{508}
1	0	0.0000	0.000
2	1	0.0004	0.080
3	2	0.0008	0.159
4	3	0.0012	0.239
5	4	0.0016	0.318
6	5	0.0020	0.398

Experiment 2

Each of Brands A–D was analyzed by crushing 1 tablet, dissolving the powder in H_2O to form a 100.0 mL solution, placing 1 mL of the solution into a flask, and then performing Steps 2–5. From the results, each brand's iron (Fe^{2+}) content, in mg/tablet, was calculated. Table 2 compares, for each brand, the calculated content with the iron (Fe^{2+}) content stated on the label.

Brand of MV tablet	Stated iron (Fe^{2+}) content (mg/tablet)	Calculated iron (Fe^{2+}) content (mg/tablet)
A	18	16.5
B	8	8.9
C	18	19.1
D	5	5.2

27. Suppose that in Experiment 1, a seventh solution had been formed, beginning with 6 mL of the stock solution. Based on Table 1, if the A_{508} of the seventh solution had been measured, it would most likely have been closest to which of the following?

A. 0.318
 B. 0.398
 C. 0.480
 D. 0.560

28. Based on Tables 1 and 2, the solution of which brand of MV tablet most likely had the greatest A_{508} value in Experiment 2?

F. Brand A
 G. Brand B
 H. Brand C
 J. Brand D

29. Which of the following graphs best shows the relationship between Fe^{2+} concentration and A_{508} in Experiment 1?

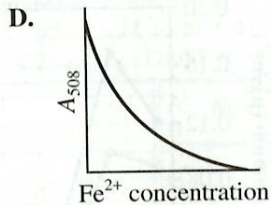
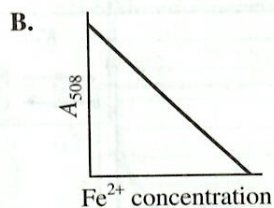
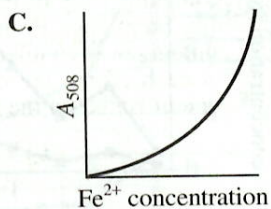
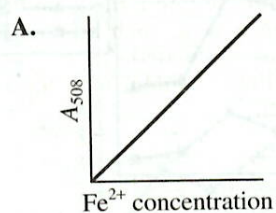

30. Consider the stock solution that was placed in a flask in Step 1. Was this solution more likely orange or colorless?
- F. Orange, because it would have absorbed visible light.
 G. Orange, because it would not have absorbed visible light.
 H. Colorless, because it would have absorbed visible light.
 J. Colorless, because it would not have absorbed visible light.

31. In Experiment 1, was the volume of H_2O that had to be added to the flask in Step 4 to form Solution 2 greater than or less than the volume of H_2O that had to be added to the flask in Step 4 to form Solution 5?

- A. Greater, because the stock solution accounted for a larger volume of Solution 2 than of Solution 5.
 B. Greater, because the stock solution accounted for a smaller volume of Solution 2 than of Solution 5.
 C. Less, because the stock solution accounted for a smaller volume of Solution 2 than of Solution 5.
 D. Less, because the stock solution accounted for a larger volume of Solution 2 than of Solution 5.

32. What was the purpose of Step 3, the addition of *o*-phen to the flask? The *o*-phen interacted with:

- F. hydroquinone to stabilize Fe^{2+} .
 G. hydroquinone to form an orange-colored complex.
 H. Fe^{2+} to stabilize hydroquinone.
 J. Fe^{2+} to form an orange-colored complex.

33. Experiments 1 and 2 were most likely related to each other in which of the following ways?

- A. The A_{508} values of Solutions 1–6 measured in Experiment 1 were used to determine the Fe^{2+} contents of Brands A–D in Experiment 2.
 B. The Fe^{2+} contents of Brands A–D calculated in Experiment 2 were used to determine the A_{508} values of Solutions 1–6 in Experiment 1.
 C. The A_{508} values of Solutions 1–6 measured in Experiment 2 were used to determine the Fe^{2+} contents of Brands A–D in Experiment 1.
 D. The Fe^{2+} contents of Brands A–D calculated in Experiment 1 were used to determine the A_{508} values of Solutions 1–6 in Experiment 2.

Passage VI

A study was done in a large city in Asia during the spring to examine the composition of airborne dust particles on 5 days of fair weather and on 5 days of dust storms. There was no precipitation on any of the study days.

Study

A device called an *impactor* (see Figure 1) was installed on the roof of a 4-story building in the center of the city. To collect airborne dust particles, the impactor drew in air at a constant rate of 1.1 L/min. A series of 8 filters inside the impactor removed particles from the air. Each filter had openings of a different uniform diameter to allow for the collection of particles belonging to 1 of 8 different size ranges, measured in micrometers (μm).

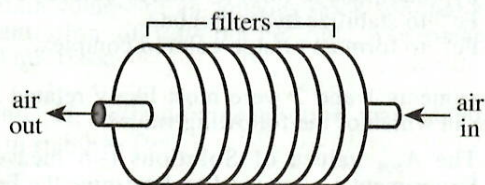

Figure 1

On each of the selected days, the impactor was operated continuously over a period that began at 9 a.m. At 3 p.m., the impactor was turned off, and the collected particles belonging to each size range were removed and then analyzed for 4 elements: silicon (Si), iron (Fe), sulfur (S), and copper (Cu). The average concentration of each element, in micrograms per cubic meter of air ($\mu\text{g}/\text{m}^3$), for the fair weather days and for the dust storm days are shown in Figures 2 and 3, respectively, for each size range.

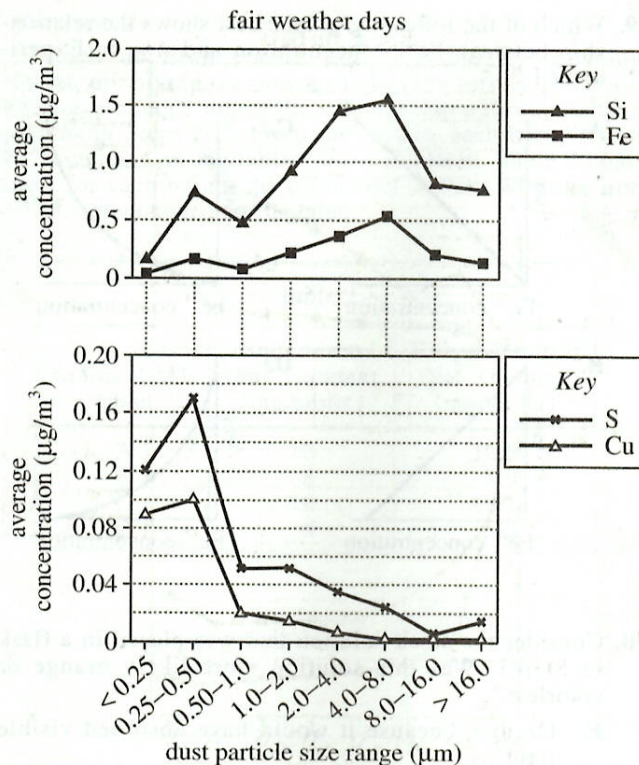

Figure 2

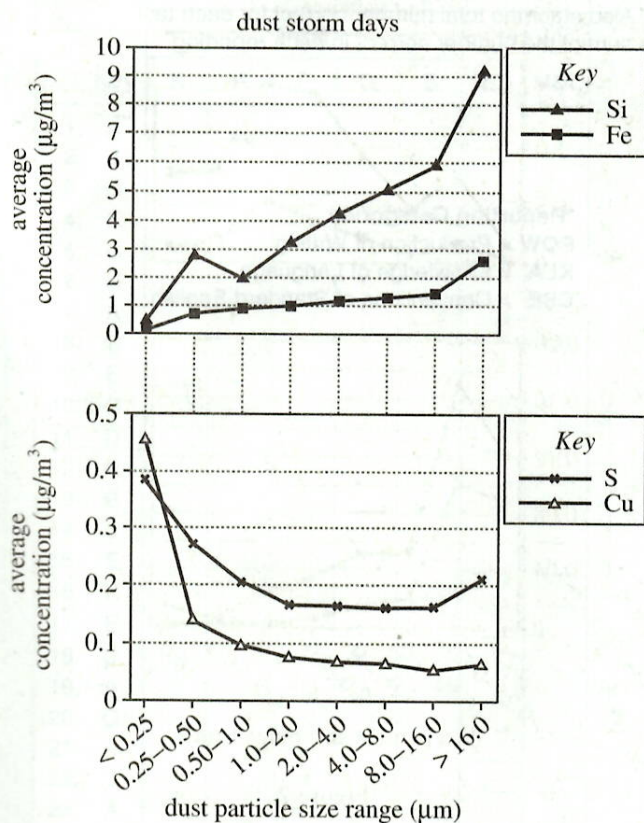

Figure 3

Figures 2 and 3 adapted from Renjian Zhang et al., "The Elemental Composition of Atmospheric Particles at Beijing during Asian Dust Events in Spring 2004." ©2010 by the Taiwan Association for Aerosol Research.

34. Consider the results of the study for the dust storm days. Did the larger dust particles ($> 2.0 \mu\text{m}$) or the smaller dust particles ($< 2.0 \mu\text{m}$) have the greater average concentrations of Si and Fe, and did the larger dust particles or the smaller dust particles have the greater average concentrations of S and Cu?

	<u>greater Si and Fe</u>	<u>greater S and Cu</u>
F.	larger dust particles	larger dust particles
G.	larger dust particles	smaller dust particles
H.	smaller dust particles	larger dust particles
J.	smaller dust particles	smaller dust particles

35. The total volume of air, in liters, that was drawn through the impactor each hour is given by which of the following expressions?

A. $1.1 \text{ L/min} \times 60 \text{ min}$
 B. $1.1 \text{ L/min} \div 60 \text{ min}$
 C. $1.1 \text{ L/min} \times 1 \text{ hr}$
 D. $1.1 \text{ L/min} \div 1 \text{ hr}$

36. Days with no precipitation were most likely chosen as study days because precipitation would have:

F. caused dust particles in the air to condense.
 G. caused dust particles in the air to vaporize.
 H. removed dust particles from the air.
 J. put more dust particles into the air.

37. What was the average mass of the $< 0.25 \mu\text{m}$ dust particles that were collected by the impactor on the fair weather days?

A. $0.5 \mu\text{g}$
 B. $5 \mu\text{g}$
 C. $50 \mu\text{g}$
 D. Cannot be determined from the given information

38. For both the fair weather days and the dust storm days, why were the results for Si and Fe plotted on a different y-axis scale than were the results for S and Cu?

F. In general, Si and Fe were present at much lesser concentrations in the particles than were S and Cu.
 G. In general, Si and Fe were present at much greater concentrations in the particles than were S and Cu.
 H. Particles containing Si and Fe belonged to smaller particle size ranges than did particles containing S and Cu.
 J. Particles containing Si and Fe belonged to larger particle size ranges than did particles containing S and Cu.

39. The average concentrations of how many of the elements were generally greater for the dust storm days than for the fair weather days?

A. 1
 B. 2
 C. 3
 D. 4

40. Based on the description of the design of the impactor, particles belonging to which size range were removed from the air by the first filter the air passed through?

F. $< 0.25 \mu\text{m}$
 G. $0.50\text{--}1.0 \mu\text{m}$
 H. $2.0\text{--}4.0 \mu\text{m}$
 J. $> 16.0 \mu\text{m}$

END OF TEST 4

STOP! DO NOT RETURN TO ANY OTHER TEST.

Scoring Keys for Form A09

Use the scoring key for each test to score your answer document for the multiple-choice tests. Mark a "1" in the blank for each question you answered correctly. Add up the numbers in each reporting category and enter the total number correct for each reporting category in the blanks provided. Also enter the total number correct for each test in the blanks provided. The total number correct for each test is the sum of the number correct in each reporting category.

Test 1: English—Scoring Key

Key	Reporting Category*		
	POW	KLA	CSE
1. C			
2. F			
3. B			
4. G			
5. B			
6. H			
7. A			
8. J			
9. A			
10. H			
11. D			
12. H			
13. B			
14. J			
15. C			
16. F			
17. B			
18. J			
19. C			
20. J			
21. B			
22. J			
23. A			
24. G			
25. B			
26. G			
27. C			
28. J			
29. A			
30. J			
31. D			
32. G			
33. A			
34. H			
35. C			
36. G			
37. C			
38. F			

Key	Reporting Category*		
	POW	KLA	CSE
39. C			
40. F			
41. B			
42. J			
43. D			
44. F			
45. C			
46. G			
47. A			
48. F			
49. D			
50. J			
51. B			
52. J			
53. C			
54. F			
55. B			
56. F			
57. C			
58. J			
59. C			
60. H			
61. B			
62. H			
63. C			
64. J			
65. D			
66. H			
67. A			
68. J			
69. C			
70. F			
71. A			
72. J			
73. A			
74. G			
75. B			

*Reporting Categories

POW = Production of Writing

KLA = Knowledge of Language

CSE = Conventions of Standard English

Number Correct (Raw Score) for:

Production of Writing (POW) _____
(23)

Knowledge of Language (KLA) _____
(12)

Conventions of Standard English (CSE) _____
(40)

Total Number Correct for English Test _____
(POW + KLA + CSE) (75)

Test 2: Mathematics—Scoring Key

Key	Reporting Category*						
	PHM					IES	MDL
	N	A	F	G	S		
1. A							
2. J	—						
3. C						—	
4. K				—			
5. C						—	—
6. H			—				
7. A						—	
8. G		—					
9. E	—						
10. G			—				
11. D						—	
12. G						—	—
13. B							
14. J		—		—			—
15. E						—	—
16. K						—	—
17. E						—	
18. J					—		
19. A				—			
20. G						—	
21. A						—	
22. J						—	—
23. A		—					—
24. G				—			
25. C						—	
26. H			—				
27. C						—	—
28. H		—					
29. D				—			—
30. G						—	—

Key	Reporting Category*						
	PHM					IES	MDL
	N	A	F	G	S		
31. D							
32. H		—					
33. A						—	
34. F			—				
35. B						—	—
36. G						—	—
37. E		—					—
38. J						—	
39. D						—	
40. K						—	—
41. B						—	
42. F			—				
43. C						—	
44. F			—				
45. A			—				
46. H						—	
47. B						—	—
48. K		—					—
49. E						—	
50. H			—				
51. D				—			
52. J						—	—
53. B				—			
54. J	—						—
55. D						—	
56. F						—	—
57. A	—						—
58. F						—	—
59. E						—	—
60. K	—						—

Combine the totals of these columns and put in the blank for PHM in the box below.

***Reporting Categories**

PHM = Preparing for Higher Math

N = Number & Quantity

A = Algebra

F = Functions

G = Geometry

S = Statistics & Probability

IES = Integrating Essential Skills

MDL = Modeling

Number Correct (Raw Score) for:

Preparing for Higher Math (PHM)
(N + A + F + G + S) _____ (35)

Integrating Essential Skills (IES) _____ (25)

Total Number Correct for Mathematics Test
(PHM + IES) _____ (60)

Modeling (MDL)
(Not included in total number correct for
mathematics test raw score) _____ (22)

Test 3: Reading—Scoring Key

Key	Reporting Category*		
	KID	CS	IKI
1. D	—		
2. H	—		
3. B	—		
4. H	—		
5. A	—		
6. J	—		
7. B	—	—	
8. J	—	—	
9. D	—	—	
10. H	—	—	
11. C	—	—	
12. G	—	—	
13. C	—	—	
14. J	—	—	—
15. B	—	—	
16. F	—	—	
17. C	—	—	
18. G	—	—	
19. D	—	—	
20. F	—	—	

Key	Reporting Category*		
	KID	CS	IKI
21. C	—	—	
22. H	—	—	
23. D	—	—	
24. F	—	—	
25. D	—	—	
26. F	—	—	
27. C	—	—	
28. G	—	—	—
29. A	—	—	—
30. G	—	—	—
31. D	—	—	—
32. F	—	—	—
33. B	—	—	—
34. G	—	—	—
35. C	—	—	—
36. J	—	—	—
37. A	—	—	—
38. H	—	—	—
39. C	—	—	—
40. G	—	—	—

***Reporting Categories**

KID = Key Ideas & Details

CS = Craft & Structure

IKI = Integration of Knowledge & Ideas

Number Correct (Raw Score) for:	
Key Ideas & Details (KID)	(23)
Craft & Structure (CS)	(11)
Integration of Knowledge & Ideas (IKI)	(6)
Total Number Correct for Reading Test (KID + CS + IKI)	(40)

Test 4: Science—Scoring Key

Key	Reporting Category*		
	IOD	SIN	EMI
1. C			—
2. F			—
3. B			—
4. J			—
5. C			—
6. H			—
7. A			—
8. F	—		
9. A	—		
10. H	—		
11. D	—		
12. F	—		
13. B	—		
14. G	—		
15. C			—
16. J		—	
17. C		—	
18. G		—	
19. C		—	
20. J		—	

Key	Reporting Category*		
	IOD	SIN	EMI
21. A	—		
22. F	—		
23. D	—		
24. G	—		
25. D	—		
26. F	—		
27. C	—	—	
28. H	—	—	
29. A	—	—	
30. J	—	—	
31. B	—	—	
32. J	—	—	
33. A	—	—	
34. G	—	—	
35. A	—	—	
36. H	—	—	
37. D	—	—	
38. G	—	—	
39. D	—	—	
40. J	—	—	

***Reporting Categories**

IOD = Interpretation of Data

SIN = Scientific Investigation

EMI = Evaluation of Models,
Inferences & Experimental Results

Number Correct (Raw Score) for:	
Interpretation of Data (IOD)	(18)
Scientific Investigation (SIN)	(12)
Evaluation of Models, Inferences & Experimental Results (EMI)	(10)
Total Number Correct for Science Test (IOD + SIN + EMI)	(40)

Explanation of Procedures Used to Obtain Scale Scores from Raw Scores

On each of the four tests on which you marked any responses, the total number of correct responses yields a raw score. Use the table below to convert your raw scores to scale scores. For each test, locate and circle your raw score or the range of raw scores that includes it in the table below. Then, read across to either outside column of the table and circle the scale score that corresponds to that raw score. As you determine your scale scores, enter them in the blanks provided on the right. The highest possible scale score for each test is 36. The lowest possible scale score for any test on which you marked any responses is 1.

Next, compute the Composite score by averaging the four scale scores. To do this, add your four scale scores and divide the sum by 4. If the resulting number ends in a fraction, round it off to the nearest whole number. (Round down any fraction less than one-half; round up any fraction that is one-half or more.) Enter this number in the blank. This is your Composite score. The highest possible Composite score is 36. The lowest possible Composite score is 1.

ACT Test A09	Your Scale Score
English	_____
Mathematics	_____
Reading	_____
Science	_____
Sum of scores _____	
Composite score (sum ÷ 4) _____	

NOTE: If you left a test completely blank and marked no items, do not list a scale score for that test. If any test was completely blank, do not calculate a Composite score.

Scale Score	Raw Scores				Scale Score
	Test 1 English	Test 2 Mathematics	Test 3 Reading	Test 4 Science	
36	74-75	59-60	39-40	40	36
35	71-73	57-58	38	39	35
34	70	56	37	38	34
33	69	54-55	36	37	33
32	—	53	35	—	32
31	68	51-52	34	36	31
30	66-67	50	33	35	30
29	65	48-49	32	34	29
28	64	45-47	31	33	28
27	62-63	42-44	—	32	27
26	61	39-41	30	31	26
25	58-60	36-38	29	30	25
24	55-57	33-35	27-28	28-29	24
23	52-54	31-32	26	26-27	23
22	49-51	29-30	24-25	24-25	22
21	47-48	28	23	22-23	21
20	44-46	26-27	22	20-21	20
19	42-43	24-25	20-21	19	19
18	40-41	21-23	19	17-18	18
17	38-39	18-20	17-18	15-16	17
16	35-37	15-17	16	14	16
15	31-34	12-14	15	12-13	15
14	28-30	9-11	13-14	11	14
13	26-27	7-8	12	10	13
12	23-25	5-6	10-11	9	12
11	20-22	4	9	8	11
10	17-19	—	7-8	7	10
9	15-16	3	6	6	9
8	12-14	—	5	5	8
7	10-11	2	—	4	7
6	8-9	—	4	3	6
5	6-7	1	3	—	5
4	5	—	2	2	4
3	3-4	—	—	1	3
2	2	—	1	—	2
1	0-1	0	0	0	1

ACT Test Information Release
Answer Document Copy Order Form
2017-2018

Directions

This booklet contains tests in English, mathematics, reading, and science. These tests measure skills and abilities highly related to high school course work and success in college. **Calculators may be used on the mathematics test only.**

The questions in each test are numbered, and the suggested answers for each question are lettered. On the answer document, the rows of ovals are numbered to match the questions, and the ovals in each row are lettered to correspond to the suggested answers.

For each question, first decide which answer is best. Next, locate on the answer document the row of ovals numbered the same as the question. Then, locate the oval in that row lettered the same as your answer. Finally, fill in the oval completely. Use a soft lead pencil and make your marks heavy and black. **Do not use ink or a mechanical pencil.**

Mark only one answer to each question. If you change your mind about an answer, erase your first mark thoroughly before marking your new answer. For each question, make certain that you mark in the row of ovals with the same number as the question.

Only responses marked on your answer document will be scored. Your score on each test will be based only on the number of questions you answer correctly during the time allowed for that test. You will **not** be penalized for guessing. **It is to your advantage to answer every question even if you must guess.**

You may work on each test **only** when the testing staff tells you to do so. If you finish a test before time is called for that test, you should use the time remaining to reconsider questions you are uncertain about in that test. You may **not** look back to a test on which time has already been called, and you may **not** go ahead to another test. To do so will disqualify you from the examination.

Lay your pencil down immediately when time is called at the end of each test. You may **not** for any reason fill in or alter ovals for a test after time is called for that test. To do so will disqualify you from the examination.

Do not fold or tear the pages of your test booklet.

**DO NOT OPEN THIS BOOKLET
UNTIL TOLD TO DO SO.**

ACT[®]

PO BOX 168
IOWA CITY, IA 52243-0168

Form 31E

ACT® Writing Test Prompt

(April 2018)

Face-to-Face Communication

Although there are still occasions when it is required, face-to-face communication seems to be decreasing. In the age of digital technology, we conduct many of our relationships through our devices instead of in person. Coworkers send e-mails instead of holding meetings. Students access assignments and lessons online that teachers once delivered in class. Friends interact through social media instead of getting together (and, sometimes, even while they are together). Perhaps our apparent preference for digital methods of communication is merely a sign of technological progress. But could this trend be harmful? What do we gain, and what do we lose, as our interpersonal relationships are increasingly conducted online instead of in person? In the digital age, it is worth considering the implications of decreasing face-to-face communication.

Read and carefully consider these perspectives. Each suggests a particular way of thinking about the implications of decreasing face-to-face communication.

Perspective One

As our methods of communication become more impersonal, our connections to each other weaken. As a result, we become self-centered, unsympathetic people.

Perspective Two

Our face-to-face communication may be decreasing, but our connections to others have never been richer. After all, we use our tools to communicate faster—and with more people—than ever before.

Perspective Three

The absence of body language and tone of voice results in regular misunderstandings. Many of our personal and even societal conflicts occur because our digital communication is commonly misinterpreted by others.

Essay Task

Write a unified, coherent essay about the implications of decreasing face-to-face communication. In your essay, be sure to:

- clearly state your own perspective on the issue and analyze the relationship between your perspective and at least one other perspective
- develop and support your ideas with reasoning and examples
- organize your ideas clearly and logically
- communicate your ideas effectively in standard written English

Your perspective may be in full agreement with any of those given, in partial agreement, or completely different.